

ROBOTICS

Product specification

IRB 2600

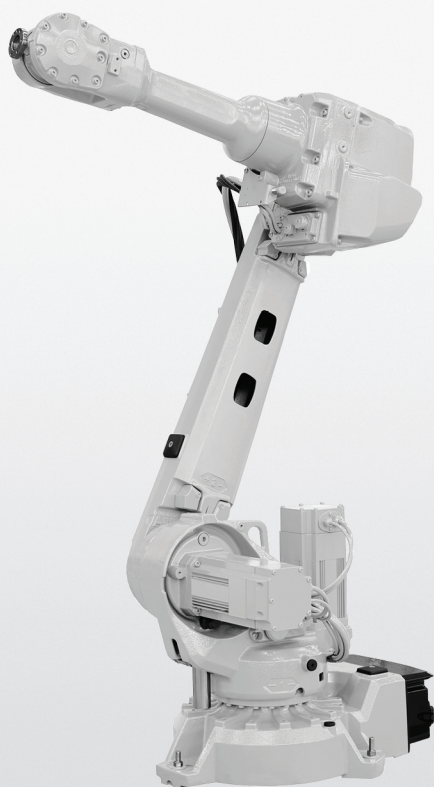

Trace back information:

Workspace OmniCore and R19C version a16

Checked in 2019-09-16

Skribenta version 5.3.012

Product specification

IRB 2600-20/1.65

IRB 2600-12/1.65

IRB 2600-12/1.85

IRB 2600ID-15/1.85

IRB 2600ID-8/2.0

Document ID: 3HAC035959-001

Revision: V

The information in this manual is subject to change without notice and should not be construed as a commitment by ABB. ABB assumes no responsibility for any errors that may appear in this manual.

Except as may be expressly stated anywhere in this manual, nothing herein shall be construed as any kind of guarantee or warranty by ABB for losses, damages to persons or property, fitness for a specific purpose or the like.

In no event shall ABB be liable for incidental or consequential damages arising from use of this manual and products described herein.

This manual and parts thereof must not be reproduced or copied without ABB's written permission.

Keep for future reference.

Additional copies of this manual may be obtained from ABB.

Original instructions.

© Copyright 2009-2019 ABB. All rights reserved.
Specifications subject to change without notice.

Table of contents

Overview of this specification	7
1 Description	11
1.1 Structure	11
1.1.1 Introduction to Structure	11
1.1.2 Different robot versions	14
1.2 Standards	20
1.2.1 Applicable standards	20
1.3 Installation	22
1.3.1 Introduction to installation	22
1.3.2 Operating requirements	23
1.3.3 Mounting the manipulator	24
1.4 Calibration and references	28
1.4.1 Calibration methods	28
1.4.2 Fine calibration	31
1.4.3 Absolute Accuracy calibration	32
1.5 Robot load and load diagrams	35
1.5.1 Introduction to Robot load and load diagrams	35
1.5.2 Load diagrams	37
1.5.3 Maximum load and moment of inertia for full and limited axis 5 (center line down) movement	46
1.5.4 Wrist torque	48
1.5.5 Maximum TCP acceleration	49
1.6 Mounting equipment	50
1.6.1 Information about mounting equipment	50
1.7 Maintenance and Troubleshooting	59
1.7.1 Introduction to Maintenance and Troubleshooting	59
1.8 Robot Motion	60
1.8.1 Introduction to Robot Motion	60
1.8.2 Performance according to ISO 9283	63
1.8.3 Velocity	64
1.8.4 Robot stopping distances and times	65
1.9 Cooling fan for axis 1-2 motor	66
1.10 Customer connections	67
1.10.1 Introduction	67
2 Specification of variants and options	69
2.1 Introduction to variants and options	69
2.2 Manipulator	70
2.3 Positioners	76
2.4 Floor cables	77
2.5 DressPack	78
2.6 Process equipment	79
2.7 User documentation	80
3 Robot description	81
3.1 Robot types	81
4 Accessories	83
4.1 Introduction to accessories	83
Index	85

This page is intentionally left blank

Overview of this specification

About this product specification

It describes the performance of the manipulator or a complete family of manipulators in terms of:

- The structure and dimensions prints
- The fulfillment of standards, safety and operating requirements
- The load diagrams, mounting or extra equipment, the motion and the robot reach
- The specification of variants and options available

Usage

Product specifications are used to find data and performance about the product, for example to decide which product to buy. How to handle the product is described in the product manual.

Users

It is intended for:

- Product managers and Product personnel
- Sales and Marketing personnel
- Order and Customer Service personnel

References

Reference	Document ID
<i>Product specification - Controller IRC5</i> IRC5 with main computer DSQC1000.	3HAC047400-001
<i>Product specification - Controller software IRC5</i> IRC5 with main computer DSQC1000 and RobotWare 5.6x.	3HAC050945-001
<i>Product specification - Controller software IRC5</i> IRC5 with main computer DSQC1000 and RobotWare 6.	3HAC050945-001
<i>Product manual - IRB 2600</i>	3HAC035504-001
<i>Product specification - Robot user documentation, IRC5 with RobotWare 6</i>	3HAC052355-001

Revisions

Revision	Description
-	First edition
A	Foundry Plus 2
B	ID-versions added
C	Minor corrections
D	<ul style="list-style-type: none"> • Table for ambient temperature adjusted • Value added to drawing, Mounting surface and bushings • Minor corrections

Continues on next page

Overview of this specification

Continued

Revision	Description
E	<ul style="list-style-type: none"> • Machinery directive updated • Foundation forces updated
F	<ul style="list-style-type: none"> • General updates and minor corrections
G	<ul style="list-style-type: none"> • General updates and minor corrections
H	<ul style="list-style-type: none"> • Minor corrections and updates
J	<ul style="list-style-type: none"> • Text for ISO test adjusted • Robot stopping distances and times for category 0 and category 1 stops are moved to a separate document, <i>Product specification - Robot stopping distances according to ISO 10218-1</i>
K	<ul style="list-style-type: none"> • Text for Foundry Plus updated. • Minor corrections and updates
L	<ul style="list-style-type: none"> • Description option 908-1 added • Option Tool Sytem TS 2600ID added • Tilting around X-axis added
M	<ul style="list-style-type: none"> • Name changed for Option 991-1, from <i>Manifold TS 2600ID</i> to <i>Tool Attachment TS 2600ID</i>. See Manipulator on page 70. • Number of M16 threaded holes in base changed.
N	<ul style="list-style-type: none"> • Illustrations for Tool flange standard/LeanID changed, see Mounting equipment on page 50
P	<ul style="list-style-type: none"> • Product data for AbsAcc added and changed, see Production data on page 34
Q	<p>Published in release R17.1. The following updates are done in this revision:</p> <ul style="list-style-type: none"> • Restriction of load diagram added. • Added data for tilted mounting, Mounting the manipulator on page 24. • Updated drawing for tool flange, Information about mounting equipment on page 50.
R	<p>Published in release R17.2. The following updates are done in this revision:</p> <ul style="list-style-type: none"> • Tool flange drawings changed • Updated list of applicable standards. • TCP acceleration information added
S	<p>Published in release R18.2. The following updates are done in this revision:</p> <ul style="list-style-type: none"> • Manipulator axes rotation direction figure updated. • Removed the phased out options: option Tool System TS 2600ID [989-1], option Tool Changer TS 2600ID [990-1], option Tool Attachment TS 2600ID [991-1], welding torch package options [878-X], option AristoMig 5000i [1029-14], current/hose set options [1030-X], and feed kit options [1033-X]. • Added pin hole dimension to tool flange/wrist dimension for IRB 2600ID.
T	<p>Published in release 19B. The following updates are done in this revision:</p> <ul style="list-style-type: none"> • Added IRB 2600 Type C-20/1.65, IRB 2600 Type C-12/1.65 to the specification. • Modify the technical data of power consumption. • Change the designation of Air hose Customer connections on page 67. • Updated information about <i>Absolute Accuracy</i>.

Continues on next page

Revision	Description
U	Published in release 19B. The following updates are done in this revision: <ul style="list-style-type: none">Type C variants (IRB 2600 Type C-20/1.65, IRB 2600 Type C-12/1.65) are removed from the manual, due to later sales start.
v	Published in release 19C. The following updates are done in this revision: <ul style="list-style-type: none">Note added about need to calibrate if the robot is other than floor mounted. See Calibration methods on page 28.

This page is intentionally left blank

1 Description

1.1 Structure

1.1.1 Introduction to Structure

Robot family

The IRB 2600 is ABB Robotics latest robot of the new sharp generation with enhanced and new capabilities. It is available in seven versions, in which IRB 2600ID-15/1.85 and IRB 2600ID-8/2.00 are with a process upper arm. The design has been optimized to make it superior for the targeted applications. The IRB 2600 will focus on further expansion in, Dispensing, Machining, Measuring, Assembly and Arc Welding applications.

Operating system

The robot is equipped with the IRC5 controller and robot control software, RobotWare. RobotWare supports every aspect of the robot system, such as motion control, development and execution of application programs, communication etc. See *Product specification - Controller IRC5 with FlexPendant*.

Safety

Safety standards valid for complete robot, manipulator and controller.

Additional functionality

For additional functionality, the robot can be equipped with optional software for application support - for example gluing and welding, communication features - network communication - and advanced functions such as multi-tasking, sensor control, etc. For a complete description on optional software, see *Product specification - Controller software IRC5*.

Protection type Foundry Plus 2

Robots with the option Foundry Plus 2 are designed for harsh environments where the robot is exposed to sprays of coolants, lubricants and metal spits that are typical for die casting applications or other similar applications.

Typical applications are spraying insertion and part extraction of die-casting machines, handling in sand casting and gravity casting, etc. (Please refer to Foundry Prime robots for washing applications or other similar applications). Special care must be taken in regard to operational and maintenance requirements for applications in foundry as well as in other applications areas. Please contact ABB Robotics Sales organization if in doubt regarding specific application feasibility for the Foundry Plus 2 protected robot.

The robot is painted with two-component epoxy on top of a primer for corrosion protection. To further improve the corrosion protection additional rust preventive are applied to exposed and crucial areas, e.g. has the tool flange a special preventive coating. Although, continuous splashing of water or other similar rust formation fluids may cause rust attach on the robots unpainted areas, joints, or

Continues on next page

1 Description

1.1.1 Introduction to Structure

Continued

other unprotected surfaces. Under these circumstances it is recommended to add rust inhibitor to the fluid or take other measures to prevent potential rust formation on the mentioned.

The entire robot is IP67 compliant according to IEC 60529 - from base to wrist, which means that the electrical compartments are sealed against water and solid contaminants. Among other things all sensitive parts are better protected than the standard offer.

Selected Foundry Plus 2 features:

- Improved sealing to prevent penetration into cavities to secure IP67
- Additional protection of cabling and electronics
- Special covers that protect cavities
- Well-proven connectors
- Nickel coated tool flange
- Rust preventives on screws, washers and unpainted/machined surfaces
- Extended service and maintenance program

The Foundry Plus 2 robot can be cleaned with appropriate washing equipment according to the robot product manual. Appropriate cleaning and maintenance is required to maintain the protection, for example can rust preventive be washed off with wrong cleaning method.

Available robot versions

The option Foundry Plus 2 might not be available for all robot versions.

See [Specification of variants and options on page 69](#) for robot versions and other options not selectable together with Foundry Plus 2.

Continues on next page

Manipulator axes

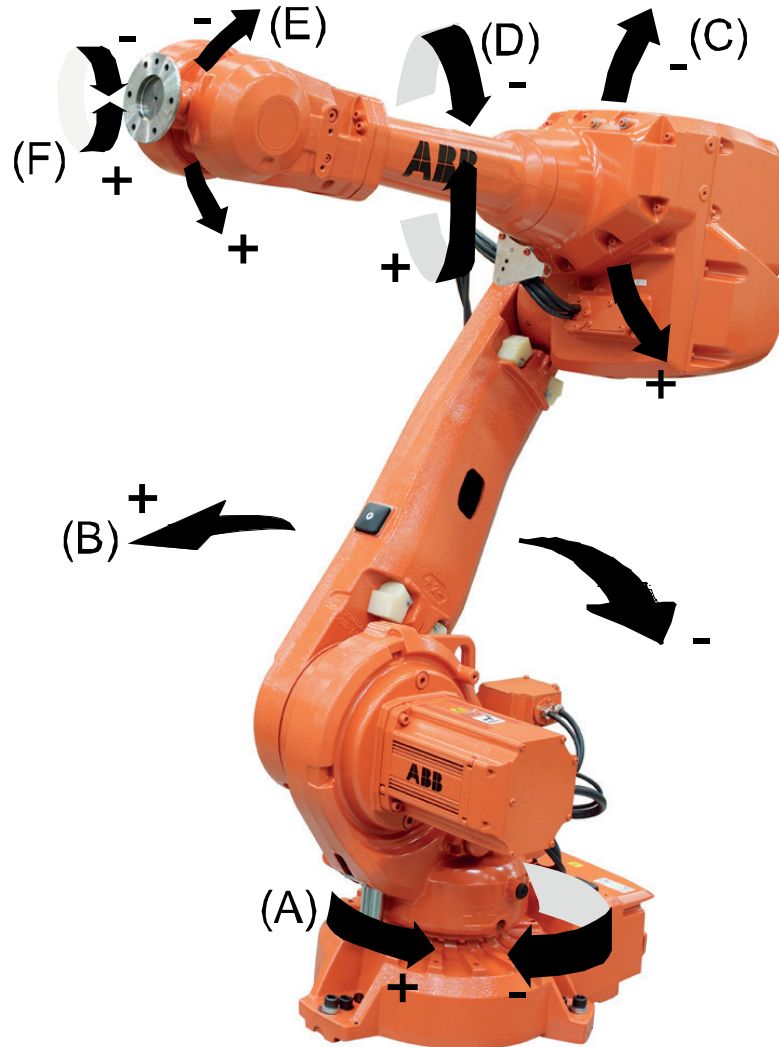

xx1800001381

Pos	Description	Pos	Description
A	Axis 1	B	Axis 2
C	Axis 3	D	Axis 4
E	Axis 5	F	Axis 6

1 Description

1.1.2 Different robot versions

1.1.2 Different robot versions

General

The IRB 2600 is available in five variants and they can be wall mounted, inverted or tilted (up to 45 degrees around the Y-axis or X-axis). See [Introduction to Robot load and load diagrams on page 35](#) for limitations.

Robot type	Handling capacity (kg)	Reach (m)
IRB 2600	20	1.65
IRB 2600	12	1.65
IRB 2600	12	1.85
IRB 2600ID	15	1.85
IRB 2600ID	8	2.00

Manipulator weight

Robot type	Weight
IRB 2600-20/1.65 IRB 2600-12/1.65	272 kg
IRB 2600-12/1.85	284 kg
IRB 2600ID-15/1.85	273 kg
IRB 2600ID-8/2.00	276 kg

Other technical data

Data	Description	Note
Airborn noise level	The sound pressure level outside the working space	< 69 dB (A) Leq (acc. to Machinery directive 2006/42/EG)

Power consumption at max load

Type of Movement	IRB 2600				
	-20/1.65	-12/1.65	-12/1.85	ID-15/1.85	ID-8/2.00
ISO Cube Max. velocity	0.941 kW	0.953 kW	0.92 kW	0.86 kW	0.86 kW

Robot in calibration position	IRB 2600				
	-20/1.65	-12/1.65	-12/1.85	ID-15/1.85	ID-8/2.00
Brakes engaged	0.145 kW	0.146 kW	0.232 kW	0.206 kW	0.207 kW
Brakes disengaged	0.429 kW	0.366 kW	0.43 kW	0.40 kW	0.39 kW

Continues on next page

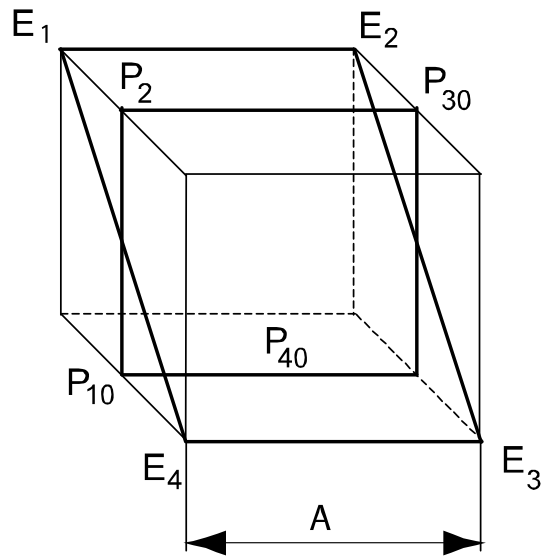

xx0900001012

Pos	Description
A	630 mm

1 Description

1.1.2 Different robot versions

Continued

Dimensions IRB 2600-20(12)/1.65

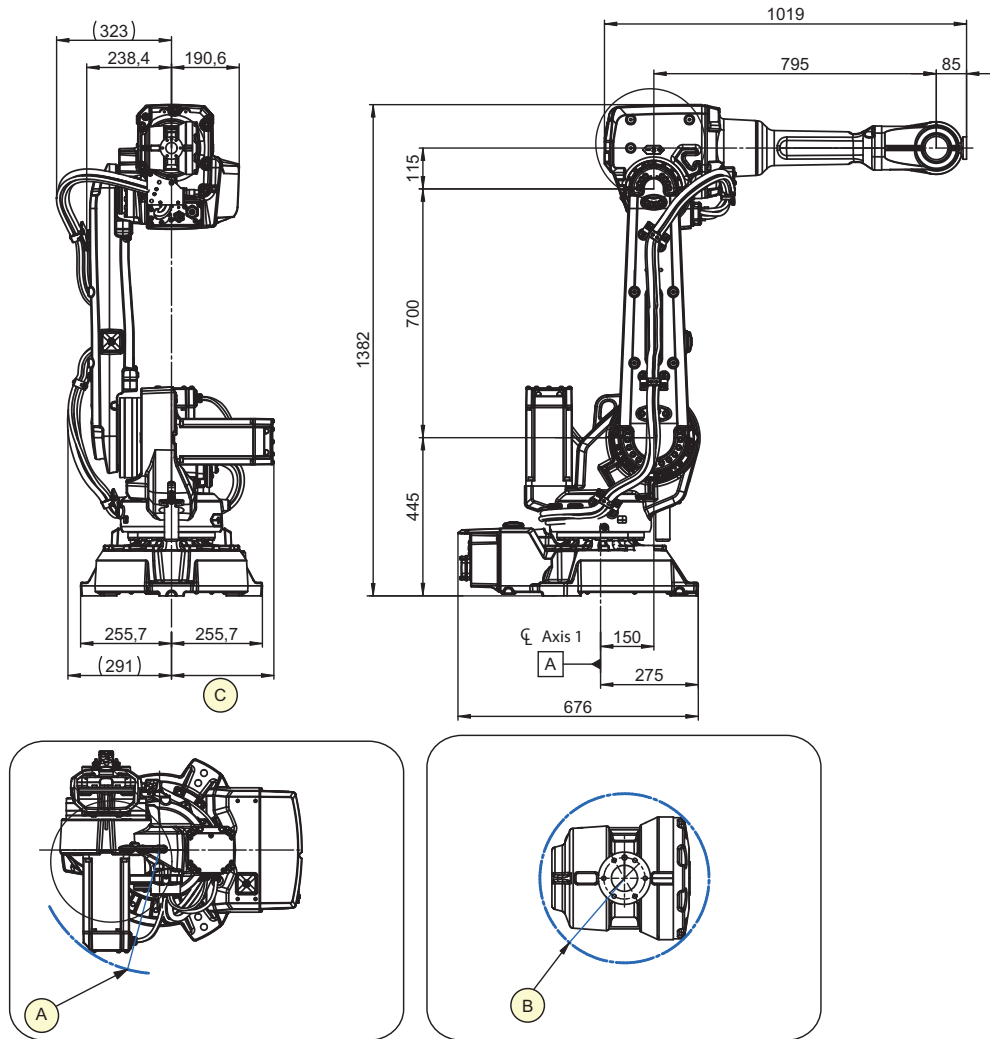

xx0900000481

Pos	Description
A	R 337 Minimum turning radius of axis 1
B	R 98 Minimum turning radius of axis 4
C	IRB 2600ID = 281 mm Other types than Type A (IRB 2600ID) = 276 mm

Continues on next page

Dimensions IRB 2600-12/1.85

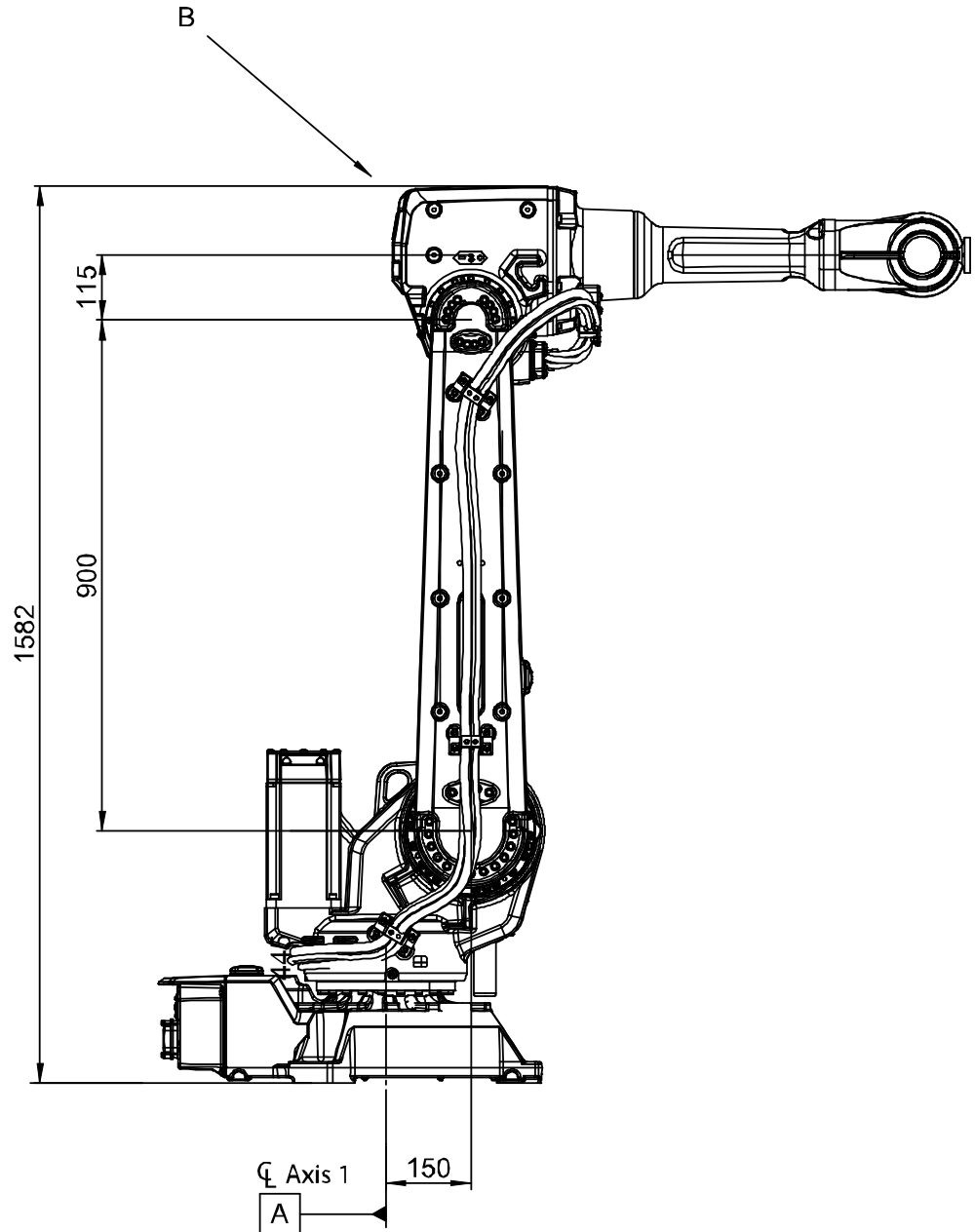

xx090000680

Pos	Description
B	For all other dimensions see IRB 2600-20(12)/1.65

Continues on next page

1 Description

1.1.2 Different robot versions

Continued

Dimensions IRB 2600ID-15/1.85

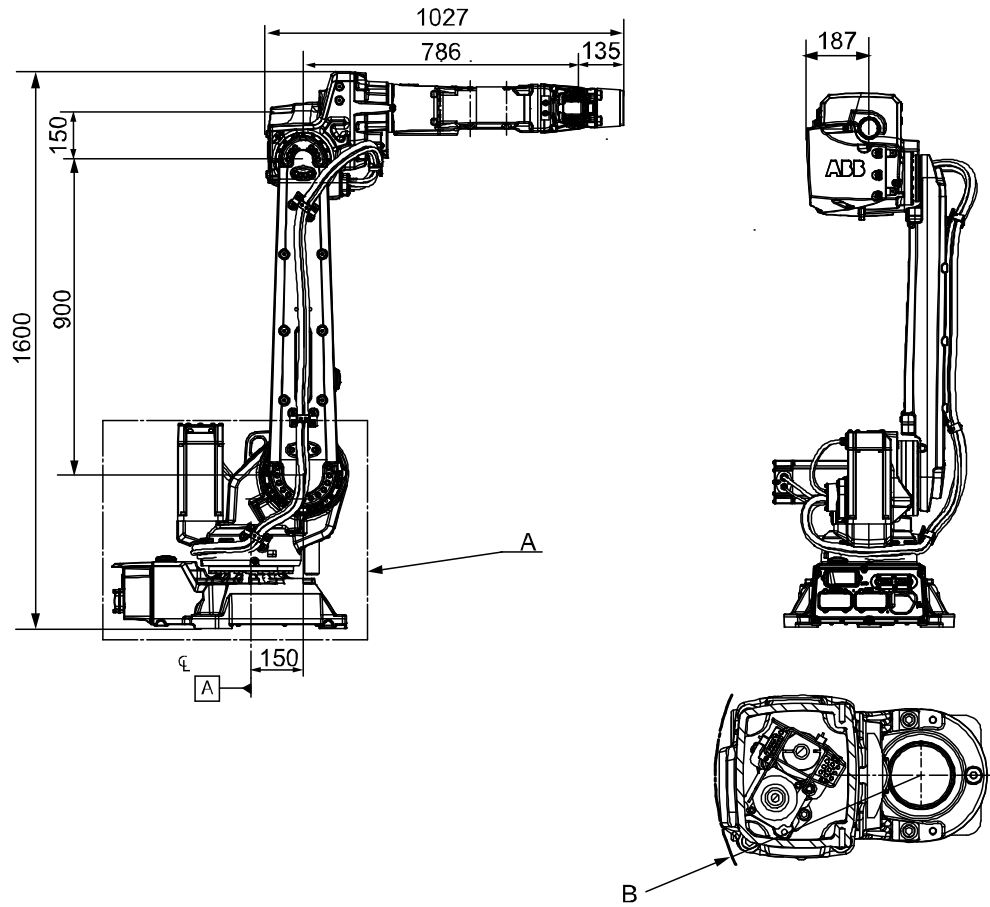

xx100000962

Pos	Description
A	For dimensions, see IRB 2600-X/1.85
B	R 172 Minimum turning radius for axis 4

Continues on next page

Dimensions IRB 2600ID-8/2.00

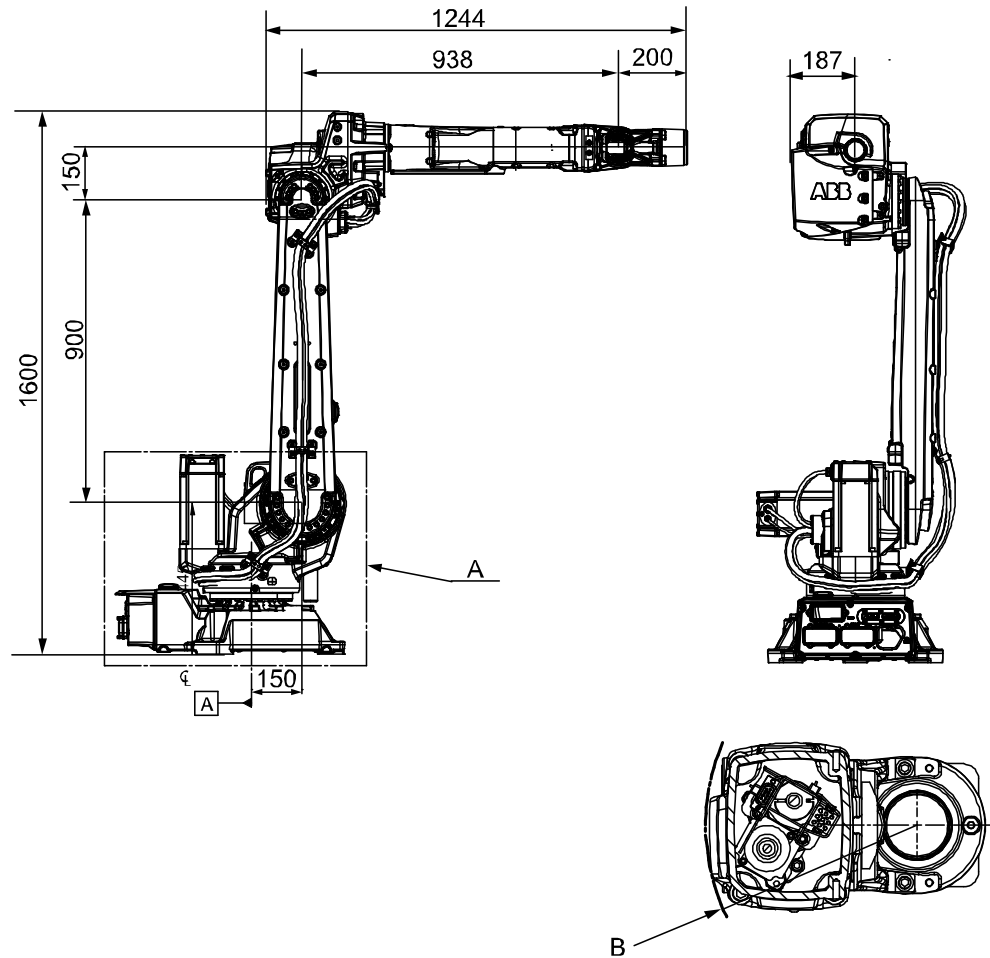

xx100000963

Pos	Description
A	For dimensions, see IRB 2600-X/1.85
B	R 172 Minimum turning radius for axis 4

1 Description

1.2.1 Applicable standards

1.2 Standards

1.2.1 Applicable standards



Note

The listed standards are valid at the time of the release of this document. Phased out or replaced standards are removed from the list when needed.

Standards, EN ISO

The product is designed in accordance with the requirements of:

Standard	Description
EN ISO 12100:2010	Safety of machinery - General principles for design - Risk assessment and risk reduction
EN ISO 13849-1:2015	Safety of machinery, safety related parts of control systems - Part 1: General principles for design
EN ISO 13850:2015	Safety of machinery - Emergency stop - Principles for design
EN ISO 10218-1:2011	Robots for industrial environments - Safety requirements -Part 1 Robot
ISO 9787:2013	Robots and robotic devices -- Coordinate systems and motion nomenclatures
ISO 9283:1998	Manipulating industrial robots, performance criteria, and related test methods
EN ISO 14644-1:2015 ⁱ	Classification of air cleanliness
EN ISO 13732-1:2008	Ergonomics of the thermal environment - Part 1
EN 61000-6-4:2007 + A1:2011 IEC 61000-6-4:2006 + A1:2010 (option 129-1)	EMC, Generic emission
EN 61000-6-2:2005 IEC 61000-6-2:2005	EMC, Generic immunity
EN IEC 60974-1:2012 ⁱⁱ	Arc welding equipment - Part 1: Welding power sources
EN IEC 60974-10:2014 ⁱⁱ	Arc welding equipment - Part 10: EMC requirements
EN IEC 60204-1:2006	Safety of machinery - Electrical equipment of machines - Part 1 General requirements
IEC 60529:1989 + A2:2013	Degrees of protection provided by enclosures (IP code)

ⁱ Only robots with protection Clean Room.

ⁱⁱ Only valid for arc welding robots. Replaces EN IEC 61000-6-4 for arc welding robots.

European standards

Standard	Description
EN 614-1:2006 + A1:2009	Safety of machinery - Ergonomic design principles - Part 1: Terminology and general principles

Continues on next page

1 Description

1.2.1 Applicable standards

Continued

Standard	Description
EN 574:1996 + A1:2008	Safety of machinery - Two-hand control devices - Functional aspects - Principles for design

Other standards

Standard	Description
ANSI/RIA R15.06	Safety requirements for industrial robots and robot systems
ANSI/UL 1740	Safety standard for robots and robotic equipment
CAN/CSA Z 434-14	Industrial robots and robot Systems - General safety requirements

1 Description

1.3.1 Introduction to installation

1.3 Installation

1.3.1 Introduction to installation

General

The IRB 2600/IRB 2600 ID is designed for floor, wall, tilted (up to 45 degrees, around the Y-axis or X-axis, for more details see *Product manual - IRB 2600*) or inverted mounting. Depending on the robot version, an end effector with max. weight of 12 or 20 kg including payload, can be mounted on the tool flange (axis 6). See [Load diagrams on page 37](#), and [Introduction to Robot Motion on page 60](#) for limitations.

Extra loads

Extra loads, which are included in the load diagrams, can be mounted on the upper arm. An extra load of 35 kg can also be mounted on the frame of axis 1. See [Information about mounting equipment on page 50](#).

Working range limitations

The working range of axis 1 can be limited by mechanical stops as option. The option Electronic Position Switches can also be used on all axes for position indication of the manipulator.

1.3.2 Operating requirements

Protection standards

Robot version		Protection Standard IEC60529
Standard manipulator		IP 67
Foundry Plus 2		IP 67
IRB 2600ID-15(8)/1.85(2.00)	Base + lower arm + wrist	IP 67
	Axis 4	IP 54

Explosive environments

The robot must not be located or operated in an explosive environment.

Ambient temperature

Description	Standard/Option	Temperature
Manipulator during operation	Standard	+ 5 °C ⁱ (41 °F) to + 45 °C (113 °F)
For the controller	Standard/Option	See <i>Product specification - Controller IRC5 with FlexPendant</i>
Complete robot during transportation and storage	Standard	- 25 °C (- 13 °F) to + 55 °C (131 °F)
For short periods (not exceeding 24 hours)	Standard	up to + 70 °C (158 °F)

ⁱ At low environmental temperature < 10° C is, as with any other machine, a warm-up phase is recommended to be run with the robot. Otherwise there is a risk that the robot stops or run with lower performance due to temperature dependent oil- and grease viscosity.

Relative humidity

Description	Relative humidity
Complete robot during operation, transportation and storage	Max. 95% at constant temperature

1 Description

1.3.3 Mounting the manipulator

1.3.3 Mounting the manipulator

Maximum load

Maximum load in relation to the base coordinate system

Floor mounted

Force	Endurance load (in operation)	Max. load (emergency stop)
Force xy	±2330 N	±5450 N
Force z	2750 ±1420 N	2750 ±3970 N
Torque xy	±3360 Nm	±7690 Nm
Torque z	±1120 Nm	±3050 Nm

Wall mounted

Force	Endurance load (in operation)	Max. load (emergency stop)
Force xy	2750 ±880 N	2750 ±4600 N
Force z	±1780 N	±4560 N
Torque xy	1470 ±1990 Nm	1470 ±5620 Nm
Torque z	±1150 Nm	±3130 Nm

Suspended mounting

Force	Endurance load (in operation)	Max. load (emergency stop)
Force xy	±2250 N	±5380 N
Force z	-2750 ±1420 N	-2750 ±4280 N
Torque xy	±3440 Nm	±7800 Nm
Torque z	±1110 Nm	±3050 Nm

Tilted mounting

Force	Endurance load (in operation)	Max. load (emergency stop)
Force xy	±2563 N	±5995 N
Force z	3025 ±4367 N	3025 ±4367 N
Torque xy	±3696 Nm	±8459 Nm
Torque z	±1232 Nm	±3355 Nm

Continues on next page

Illustration

The figures below shows IRB 2600 Standard but are also valid for IRB 2600ID.

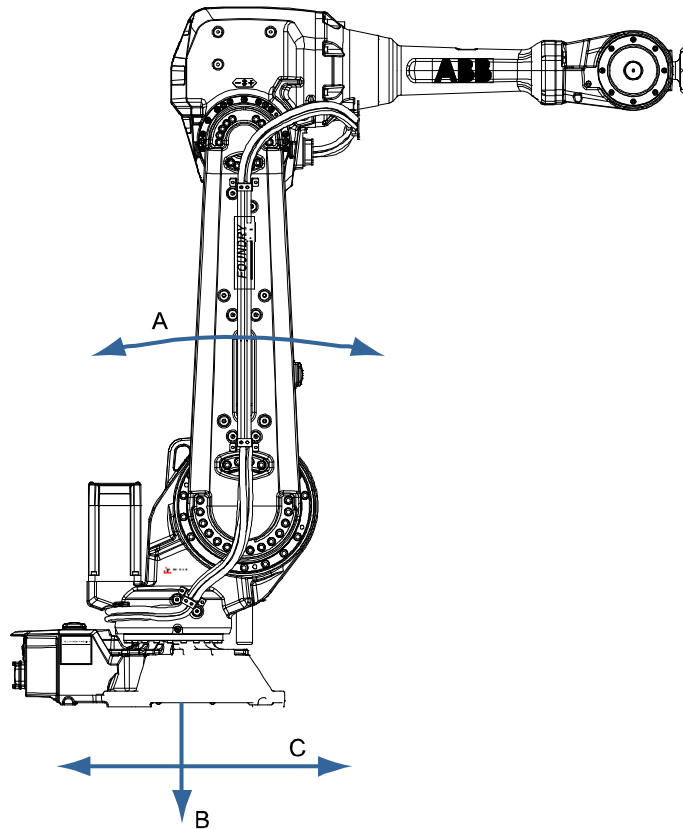

xx0900000056

A	Torque _{xy} (T_{xy})
B	Force _z (F_z)
C	Force _{xy} (F_{xy})

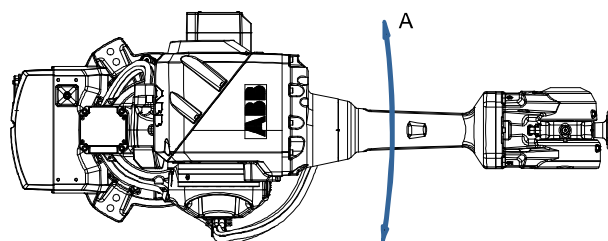

xx0900000057

A	Torque _z (T_z)
---	-------------------------------

Note regarding M_{xy} and F_{xy}

The bending torque (M_{xy}) can occur in any direction in the XY-plane of the base coordinate system. The same applies to the transverse force (F_{xy}).

Continues on next page

1 Description

1.3.3 Mounting the manipulator

Continued

Fastening holes robot base

Only 3 screws ($\varnothing 500$) are required for fastening the robot.

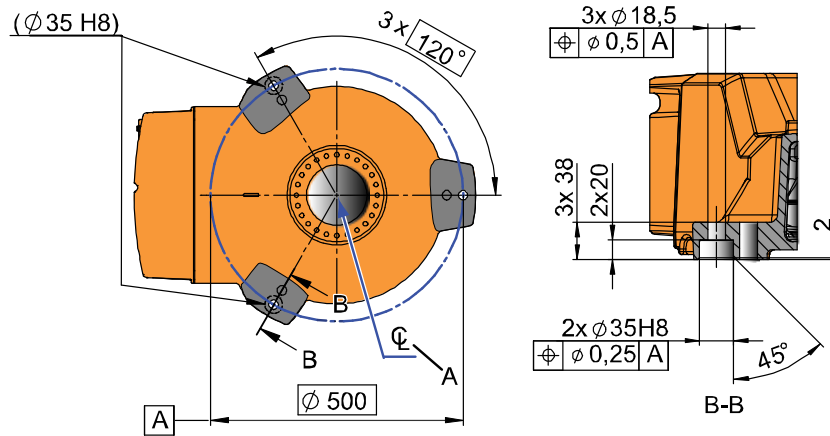

xx0900000193

Attachment bolts, specification

The table below specifies required bolts and washers for securing the robot at installation site

Specification	Description
Attachment bolts, 3 pcs	M16 x 60 (installation directly on foundation) M16 x 70/80 (installation on foundation or base plate, using guiding sleeves)
Washers, 3 pcs	17 x 30 x 3
Quality	Quality 8.8
Tightening torque	200 Nm



Note

For best AbsAcc performance, use the guide holes according to the preceding figure.

Mounting surface and bushings



Note

Only the three outer holes are used to secure the robot!

Continues on next page

1 Description

1.3.3 Mounting the manipulator

Continued

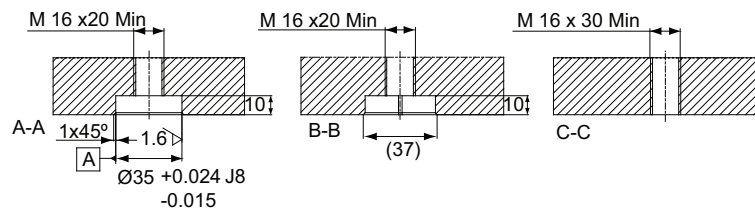
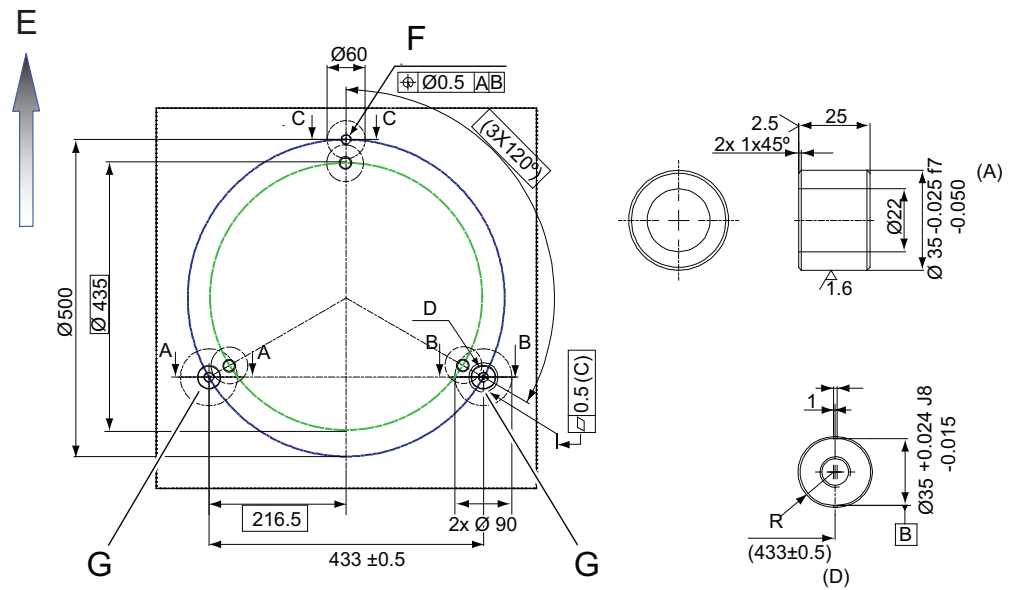

xx0900000392

Pos	Description
(C)	3x common zone
E	Position of the front of the robot
F	1xM16, depth 30 minimum
G	Guide sleeves (2 pcs)

1 Description

1.4.1 Calibration methods

1.4 Calibration and references

1.4.1 Calibration methods

Overview

This section specifies the different types of calibration and the calibration methods that are supplied by ABB.

The original calibration data delivered with the robot is generated when the robot is floor mounted. If the robot is not floor mounted, then the robot accuracy could be affected. The robot needs to be calibrated after it is mounted.

More information is available in the product manual.

Types of calibration

Type of calibration	Description	Calibration method
Standard calibration	The calibrated robot is positioned at calibration position. Standard calibration data is found on the SMB (serial measurement board) or EIB in the robot. For robots with RobotWare 5.04 or older, the calibration data is delivered in a file, calib.cfg, supplied with the robot at delivery. The file identifies the correct resolver/motor position corresponding to the robot home position.	Axis Calibration or Calibration Pendulum ¹

Continues on next page

Type of calibration	Description	Calibration method
Absolute accuracy calibration (optional)	<p>Based on standard calibration, and besides positioning the robot at synchronization position, the Absolute accuracy calibration also compensates for:</p> <ul style="list-style-type: none"> • Mechanical tolerances in the robot structure • Deflection due to load <p>Absolute accuracy calibration focuses on positioning accuracy in the Cartesian coordinate system for the robot.</p> <p>Absolute accuracy calibration data is found on the SMB (serial measurement board) in the robot.</p> <p>For robots with RobotWare 5.05 or older, the absolute accuracy calibration data is delivered in a file, <code>absacc.cfg</code>, supplied with the robot at delivery. The file replaces the <code>calib.cfg</code> file and identifies motor positions as well as absolute accuracy compensation parameters.</p> <p>A robot calibrated with Absolute accuracy has a sticker next to the identification plate of the robot.</p> <p>To regain 100% Absolute accuracy performance, the robot must be recalibrated for absolute accuracy after repair or maintenance that affects the mechanical structure.</p> <div style="border: 1px solid black; padding: 5px; margin-top: 10px;">  <div style="display: inline-block; vertical-align: middle;"> <p style="margin: 0;">ABSOLUTE ACCURACY</p> <p style="font-size: small; margin: 0;">3HAC 14257-1</p> </div> </div> <p style="font-size: x-small; margin-top: 5px;">xx0400001197</p>	CalibWare

ⁱ The robot is calibrated by either Calibration Pendulum or Axis Calibration at factory. Always use the same calibration method as used at the factory. Information about valid calibration method is found on the calibration label or in the calibration menu on the FlexPendant. If no data is found related to standard calibration, Calibration Pendulum is used as default.

Brief description of calibration methods

Calibration Pendulum method

Calibration Pendulum is a standard calibration method for calibration of all ABB robots (except IRB 6400R, IRB 640, IRB 1400H, and IRB 4400S).

Two different routines are available for the Calibration Pendulum method:

- Calibration Pendulum II
- Reference calibration

The calibration equipment for Calibration Pendulum is delivered as a complete toolkit, including the *Operating manual - Calibration Pendulum*, which describes the method and the different routines further.

Axis Calibration method

Axis Calibration is a standard calibration method for calibration of IRB 2600/IRB 2600 ID and is the most accurate method for the standard calibration. It is the recommended method in order to achieve proper performance.

Continues on next page

1 Description

1.4.1 Calibration methods

Continued

The following routines are available for the Axis Calibration method:

- Fine calibration
- Update revolution counters
- Reference calibration

The calibration equipment for Axis Calibration is delivered as a toolkit.

The actual instructions of how to perform the calibration procedure and what to do at each step is given on the FlexPendant. You will be guided through the calibration procedure, step by step.

CalibWare - Absolute Accuracy calibration

The CalibWare tool guides through the calibration process and calculates new compensation parameters. This is further detailed in the *Application manual - CalibWare Field*.

If a service operation is done to a robot with the option Absolute Accuracy, a new absolute accuracy calibration is required in order to establish full performance. For most cases after replacements that do not include taking apart the robot structure, standard calibration is sufficient.

1.4.2 Fine calibration

General

Fine calibration is made using the Calibration Pendulum, see *Operating manual - Calibration Pendulum*.

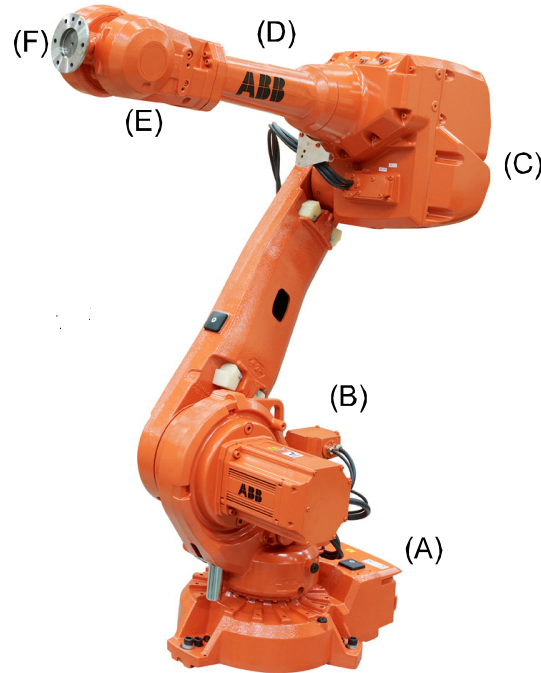

xx080000437

Pos	Description	Pos	Description
A	Axis 1	B	Axis 2
C	Axis 3	D	Axis 4
E	Axis 5	F	Axis 6

Calibration

Calibration	Position
Calibration of all axes	All axes are in zero position
Calibration of axis 1 and 2	Axis 1 and 2 in zero position
	Axis 3 to 6 in any position
Calibration of axis 1	Axis 1 in zero position
	Axis 2 to 6 in any position

1 Description

1.4.3 Absolute Accuracy calibration

1.4.3 Absolute Accuracy calibration

Purpose

Absolute Accuracy is a calibration concept that improves TCP accuracy. The difference between an ideal robot and a real robot can be several millimeters, resulting from mechanical tolerances and deflection in the robot structure. Absolute Accuracy compensates for these differences.

Here are some examples of when this accuracy is important:

- Exchangeability of robots
- Offline programming with non or minimum touch-up
- Online programming with accurate movement and reorientation of tool
- Accurate cell alignment for MultiMove coordinated motion
- Programming with accurate offset movement in relation to eg. vision system or offset programming
- Re-use of programs between applications

The option Absolute Accuracy is integrated in the controller algorithms and does not need external equipment or calculation.



Note

The performance data is applicable to the corresponding RobotWare version of the individual robot.

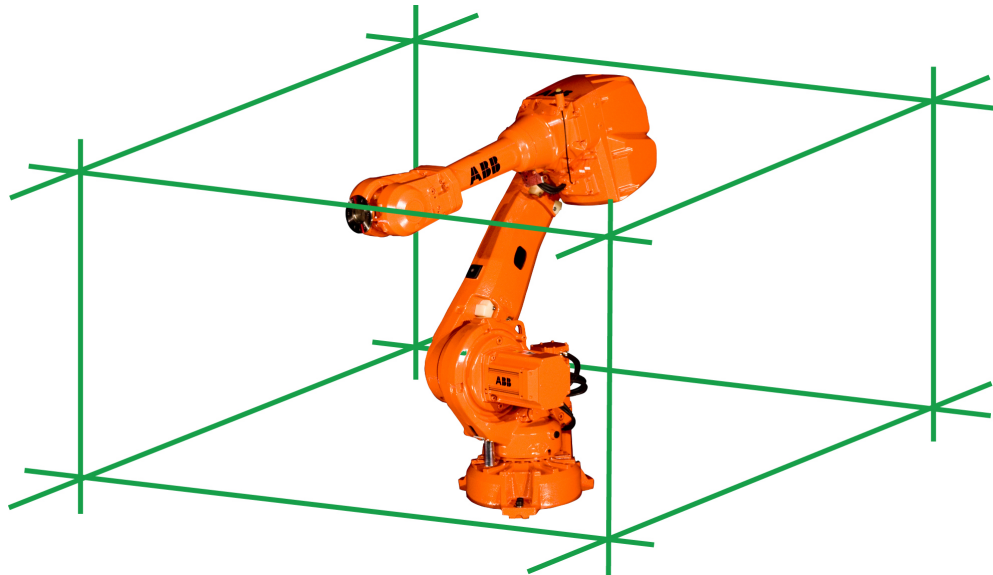

xx090000073

What is included

Every Absolute Accuracy robot is delivered with:

- compensation parameters saved on the robot's serial measurement board
- a birth certificate representing the Absolute Accuracy measurement protocol for the calibration and verification sequence.

Continues on next page

A robot with Absolute Accuracy calibration is marked on the manipulator. Absolute Accuracy supports both floor mounted and inverted installations. The compensation parameters differ depending on if the robot is floor mounted or inverted.

When is Absolute Accuracy being used

Absolute Accuracy works on a robot target in Cartesian coordinates, not on the individual joints. Therefore, joint based movements (e.g. `MoveAbsJ`) will not be affected.

If the robot is inverted, the Absolute Accuracy calibration must be performed when the robot is inverted.

Absolute Accuracy active

Absolute Accuracy will be active in the following cases:

- Any motion function based on robtargets (e.g. `MoveL`) and `ModPos` on robtargets
- Reorientation jogging
- Linear jogging
- Tool definition (4, 5, 6 point tool definition, room fixed TCP, stationary tool)
- Work object definition

Absolute Accuracy not active

The following are examples of when Absolute Accuracy is not active:

- Any motion function based on a jointtarget (`MoveAbsJ`)
- Independent joint
- Joint based jogging
- Additional axes
- Track motion



Note

In a robot system with, for example, an additional axis or track motion, the Absolute Accuracy is active for the manipulator but not for the additional axis or track motion.

RAPID instructions

There are no RAPID instructions included in this option.

MultiMove

If the main robot in a MultiMove system has the Absolute Accuracy option, it opens up Absolute Accuracy capability for all the robots in the system. However, each robot needs to be calibrated individually.



Note

Note that this is the only RobotWare option that is relevant for an additional robot.

Continues on next page

1 Description

1.4.3 Absolute Accuracy calibration

Continued



Note

It is possible to mix robots with and without the option Absolute Accuracy arbitrarily in a MultiMove system.

Production data

Typical production data regarding calibration are:

Robot	Positioning accuracy (mm)		
	Average	Max	% Within 1 mm
IRB 2600-20/1.65 IRB 2600-12/1.65 IRB 2600-12/1.85 IRB 2600ID-15/1.85	0.25	0.65	100
IRB 2600ID-8/2.00	0.35	0.85	100

1.5 Robot load and load diagrams

1.5.1 Introduction to Robot load and load diagrams

Information



WARNING

It is very important to always define correct actual load data and correct payload of the robot. Incorrect definitions of load data can result in overloading of the robot.

If incorrect load data and/or loads are outside load diagram is used the following parts can be damaged due to overload:

- motors
- gearboxes
- mechanical structure



WARNING

In the robot system the service routine LoadIdentify is available, which allows the user to make an automatic definition of the tool and load, to determine correct load parameters.

See *Operating manual - IRC5 with FlexPendant*, for detailed information.



WARNING

Robots running with incorrect load data and/or with loads outside diagram, will not be covered by robot warranty.

General

The load diagrams include a nominal payload inertia, J_0 of 0.2 kgm² for all variants, also extra load at the upper arm housing and wrist are included according to table below. At different moment of inertia the load diagram will be changed. For robots that are allowed tilted, wall or inverted mounted, the load diagrams as given are valid and thus it is also possible to use RobotLoad within those tilt and axis limits.

Robot	Extra arm load	Load at wrist
IRB 2600-20/1.65 IRB 2600-12/1.85 IRB 2600ID-15/1.85	10 kg	1 kg
IRB 2600-12/1.65 IRB 2600ID-8/2.00	15 kg	1 kg

Control of load case by "RobotLoad"

To easily control a specific load case, use the calculation program ABB RobotLoad. Contact your local ABB organization for more information.

Continues on next page

1 Description

1.5.1 Introduction to Robot load and load diagrams

Continued

The result from RobotLoad is only valid within the maximum loads and tilt angles. There is no warning if the maximum permitted armload is exceeded. For over load cases and special applications, contact ABB for further analysis.

1.5.2 Load diagrams

IRB 2600 - 20/1.65

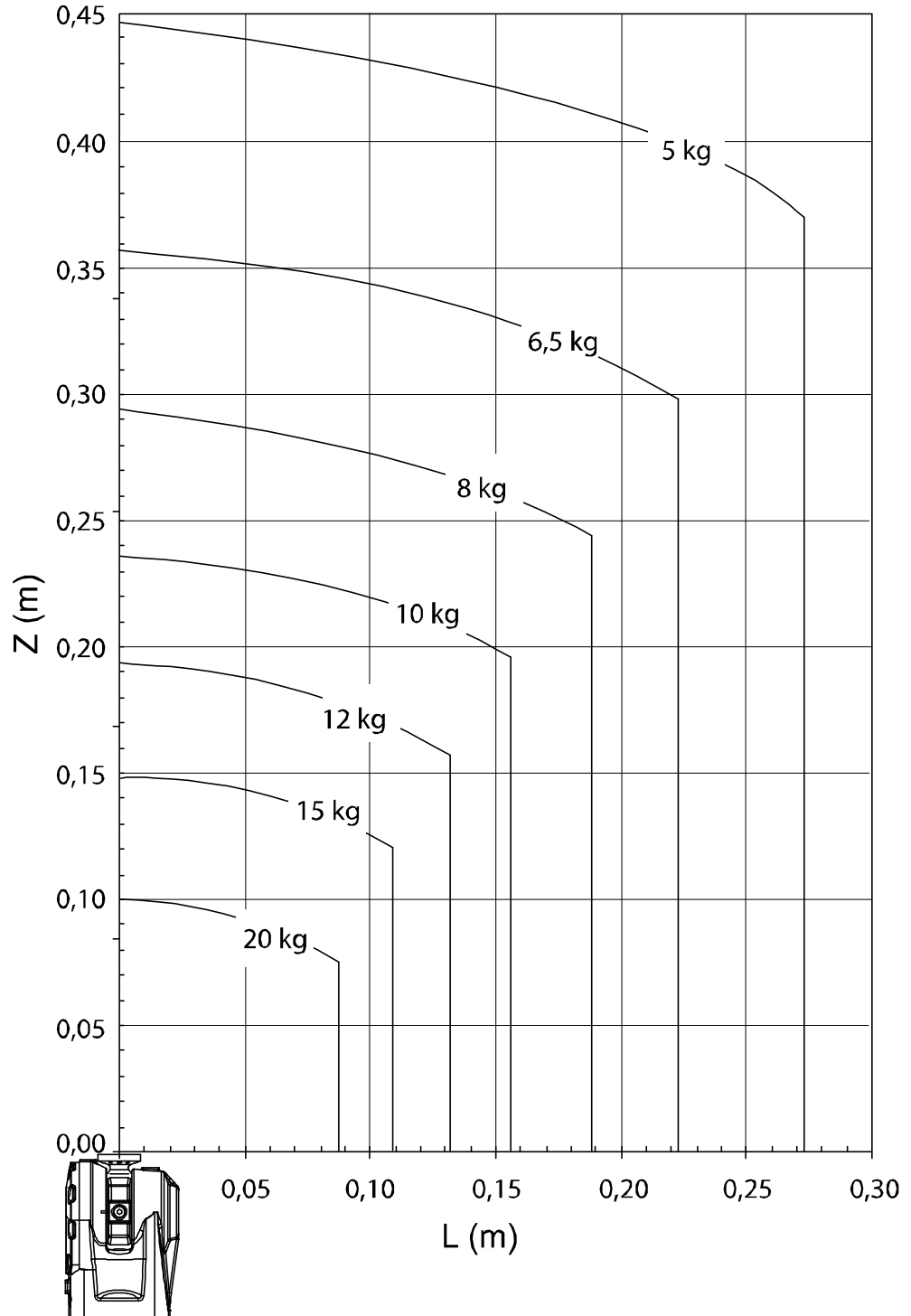

xx0900000701

Extra load of 10 kg at the upper arm housing and 1 kg at wrist included in the load diagram.

Continues on next page

1 Description

1.5.2 Load diagrams

Continued

IRB 2600 - 20/1.65 "Vertical wrist" ($\pm 10^\circ$)

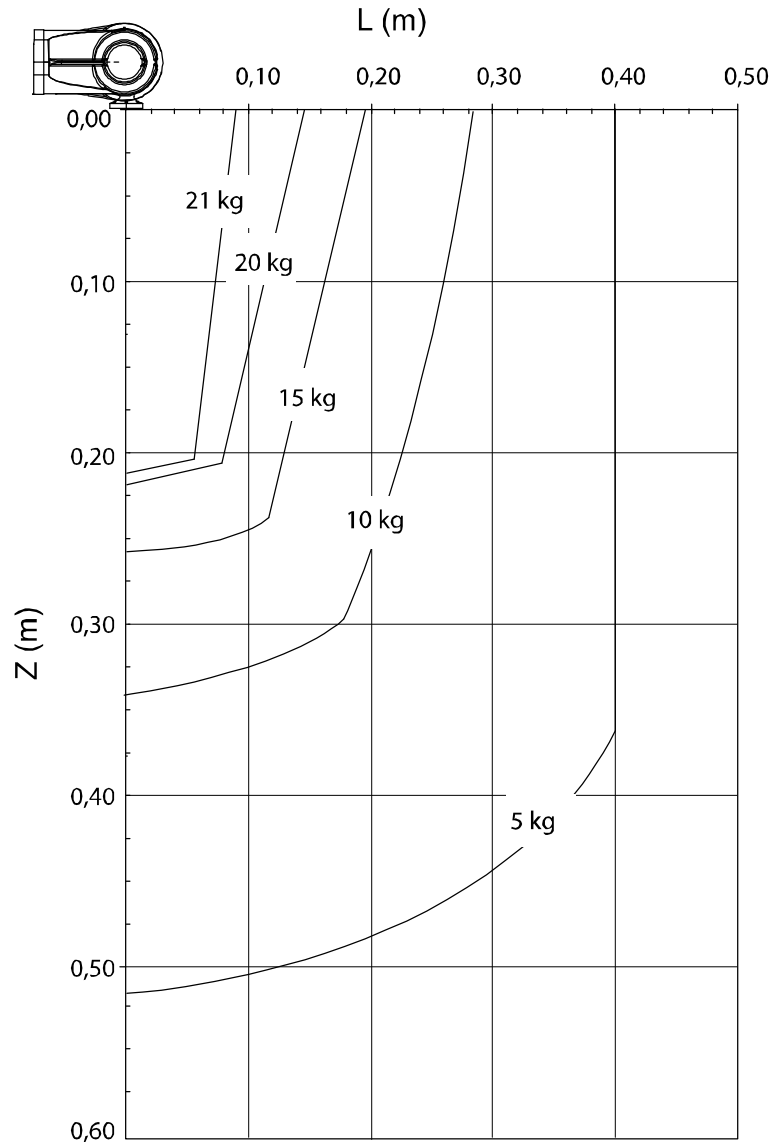

xx0900000725

Extra load of 10 kg at the upper arm housing and 1 kg at wrist included in the load diagram.

For wrist down $\pm 0^\circ$ deviation from vertical line.

	Description
Max load	22 kg
Z _{max}	0.134 m
L _{max}	0.031 m

Continues on next page

IRB 2600 - 12/1.65

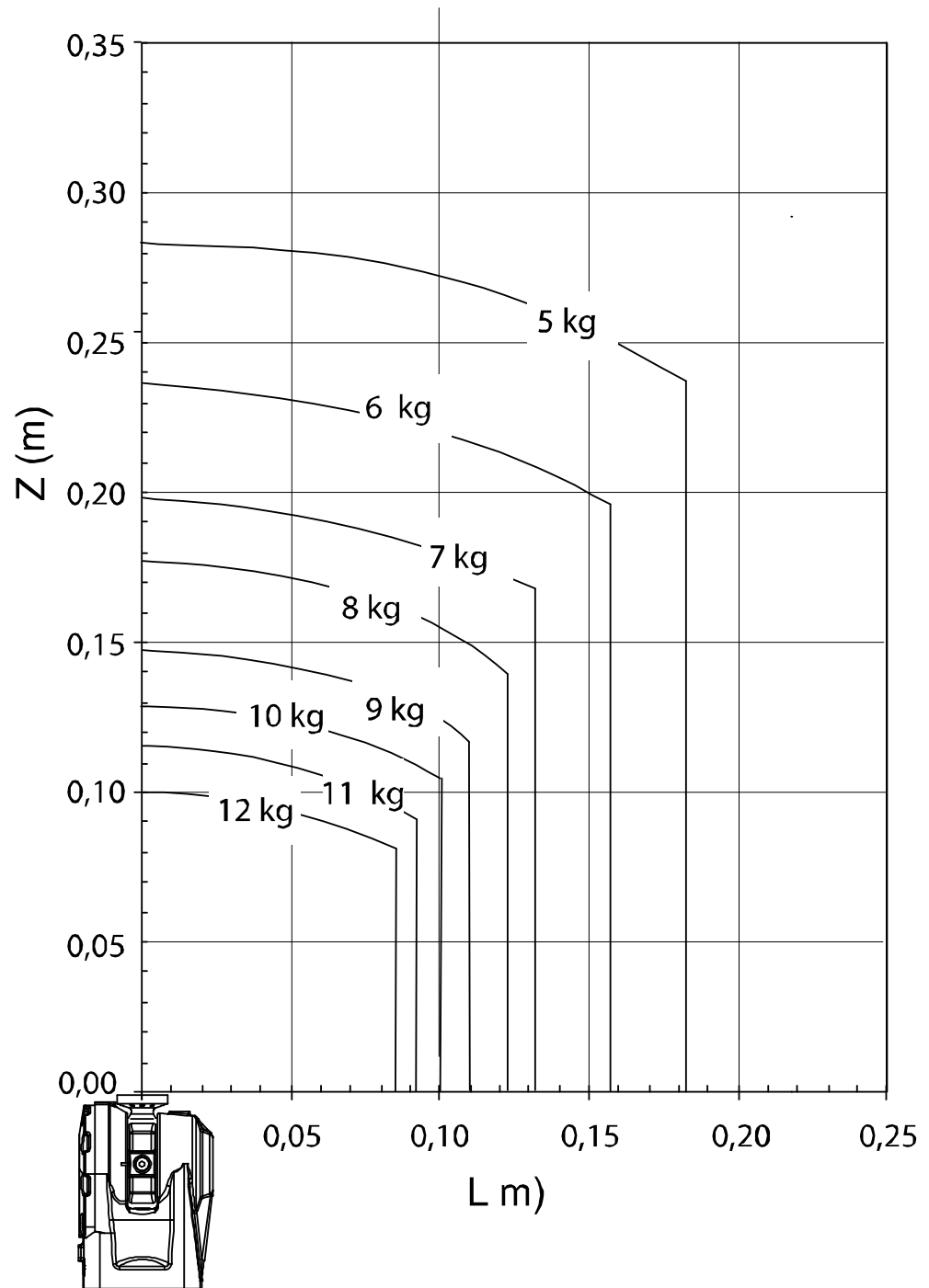

xx0900000726

Extra load of 15 kg at the upper arm housing and 1 kg at wrist included in the load diagram.

Load diagram "Vertical wrist" is not available for IRB 2600-12/1.65.

Continues on next page

1 Description

1.5.2 Load diagrams

Continued

IRB 2600 - 12/1.85

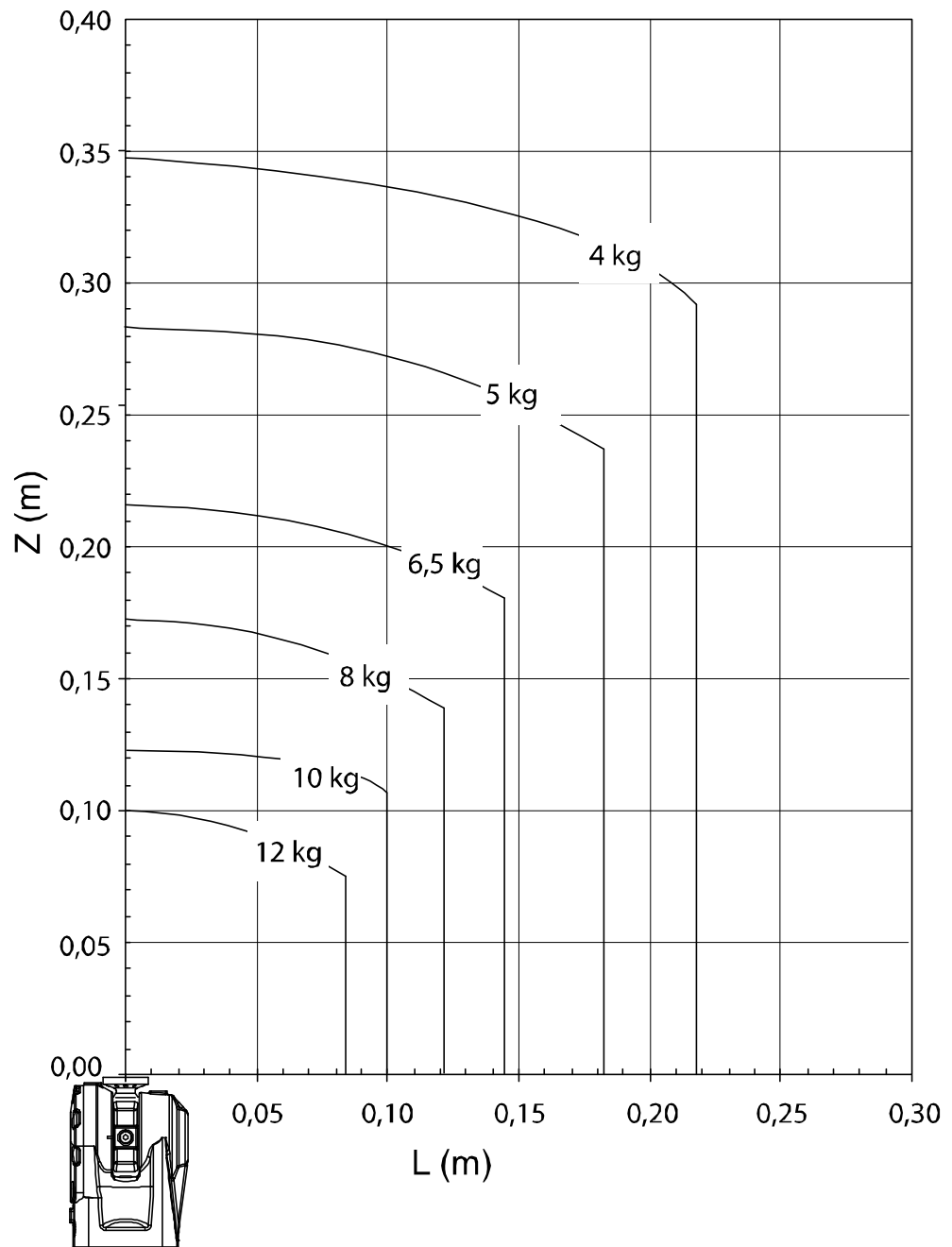

xx090000708

Extra load of 10 kg at the upper arm housing and 1 kg at wrist included in the load diagram.

Continues on next page

IRB 2600 - 12/1.85 "Vertical wrist" ($\pm 10^\circ$)

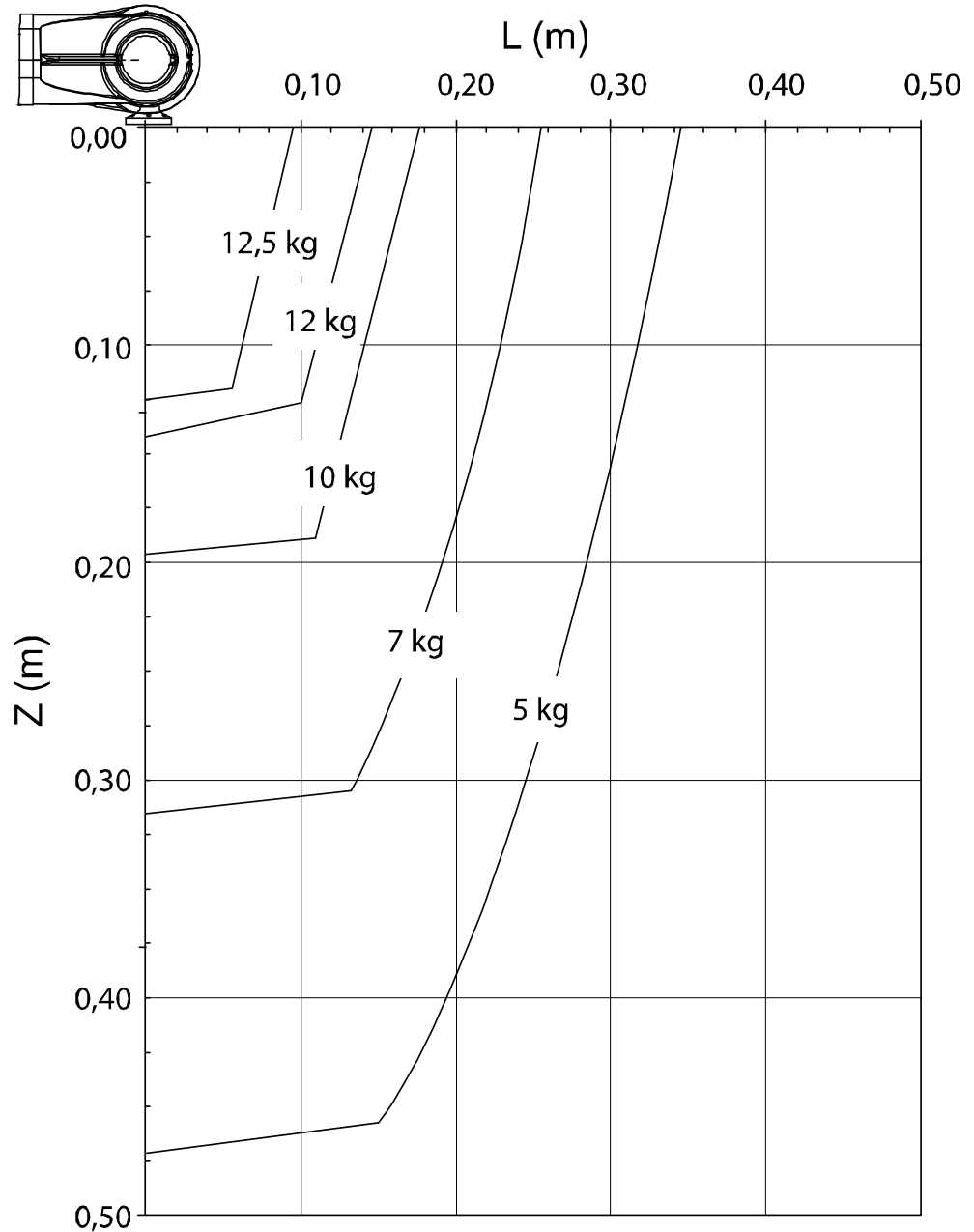

xx0900000709

Extra load of 10 kg at the upper arm housing and 1 kg at wrist included in the load diagram.

For wrist down $\pm 0^\circ$ deviation from vertical line.

	Description
Max load	13 kg
Z _{max}	0.131 m
L _{max}	0.040 m

Continues on next page

1 Description

1.5.2 Load diagrams

Continued

IRB 2600ID - 15/1.85

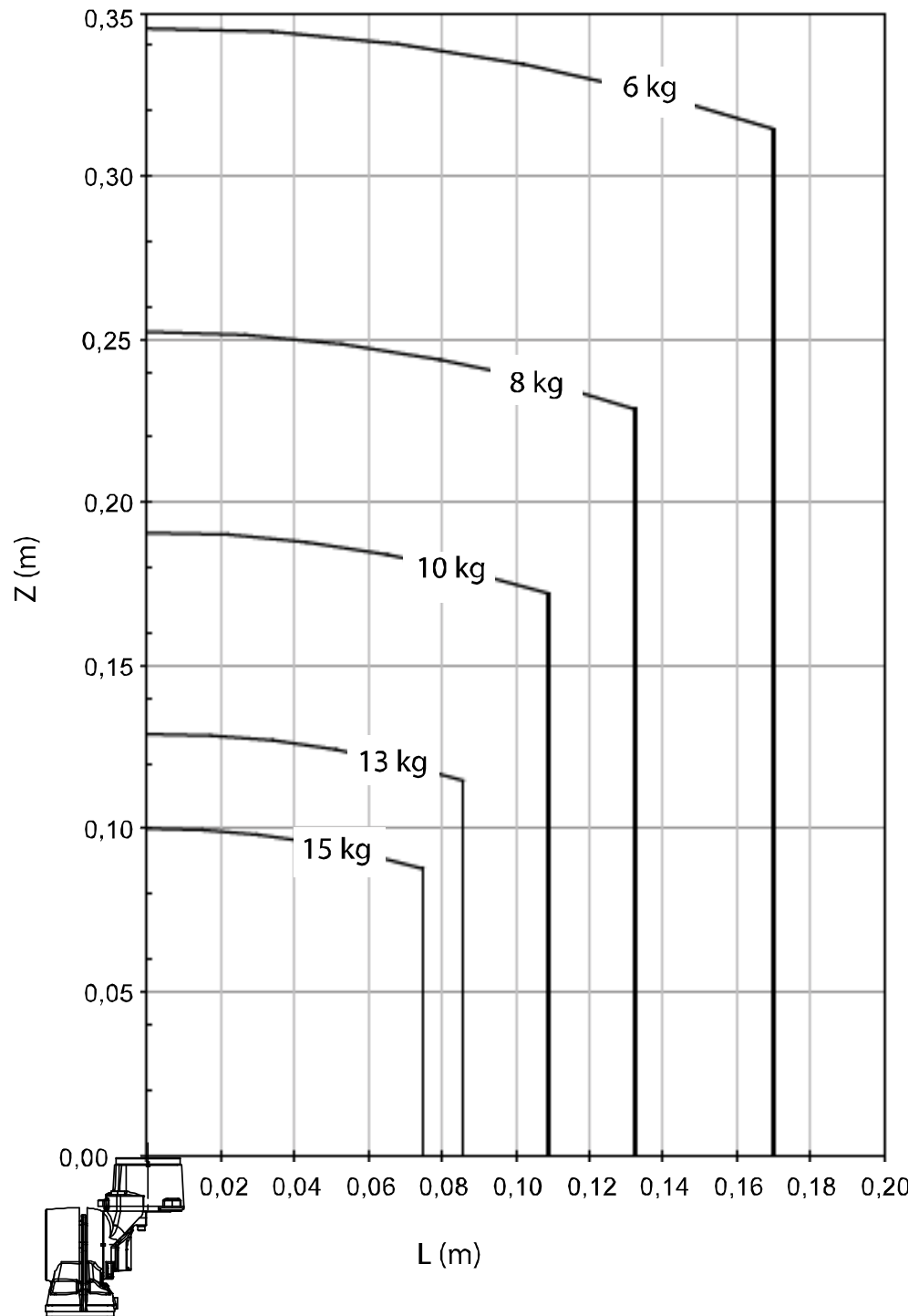

xx1000000966

Extra load of 10 kg at upper arm and 1 kg at wrist included in the load diagram.

Continues on next page

IRB 2600ID-15/1.85 "Vertical wrist" ($\pm 10^\circ$)

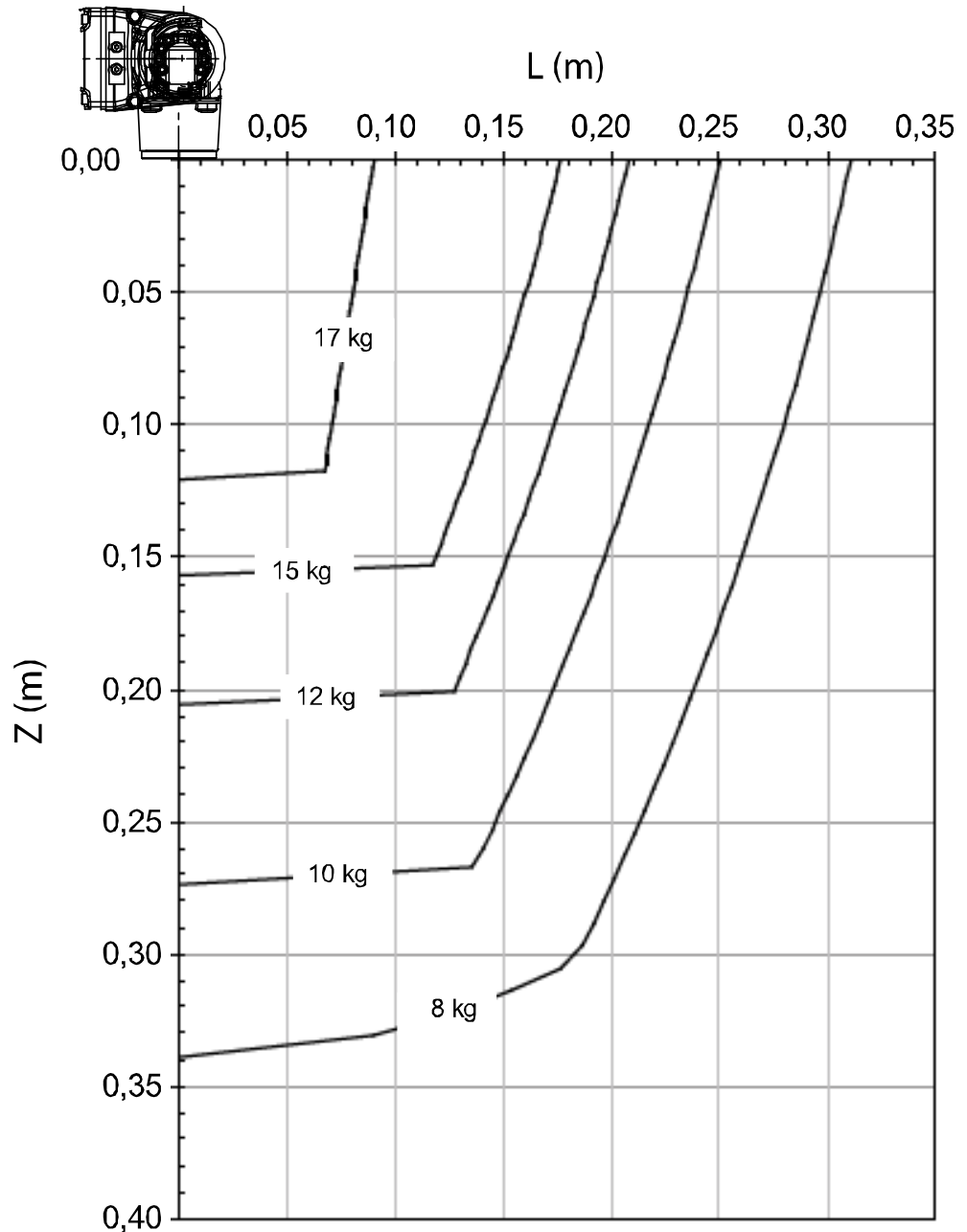

xx100000976

Extra load of 10 kg at the upper arm housing and 1 kg at wrist included in the load diagram.

For wrist down $\pm 0^\circ$ deviation from the vertical line.

	Description
Max load	16.5 kg
Z _{max}	0.113 m
L _{max}	0.057 m

Continues on next page

1 Description

1.5.2 Load diagrams

Continued

IRB 2600ID - 8/2.00

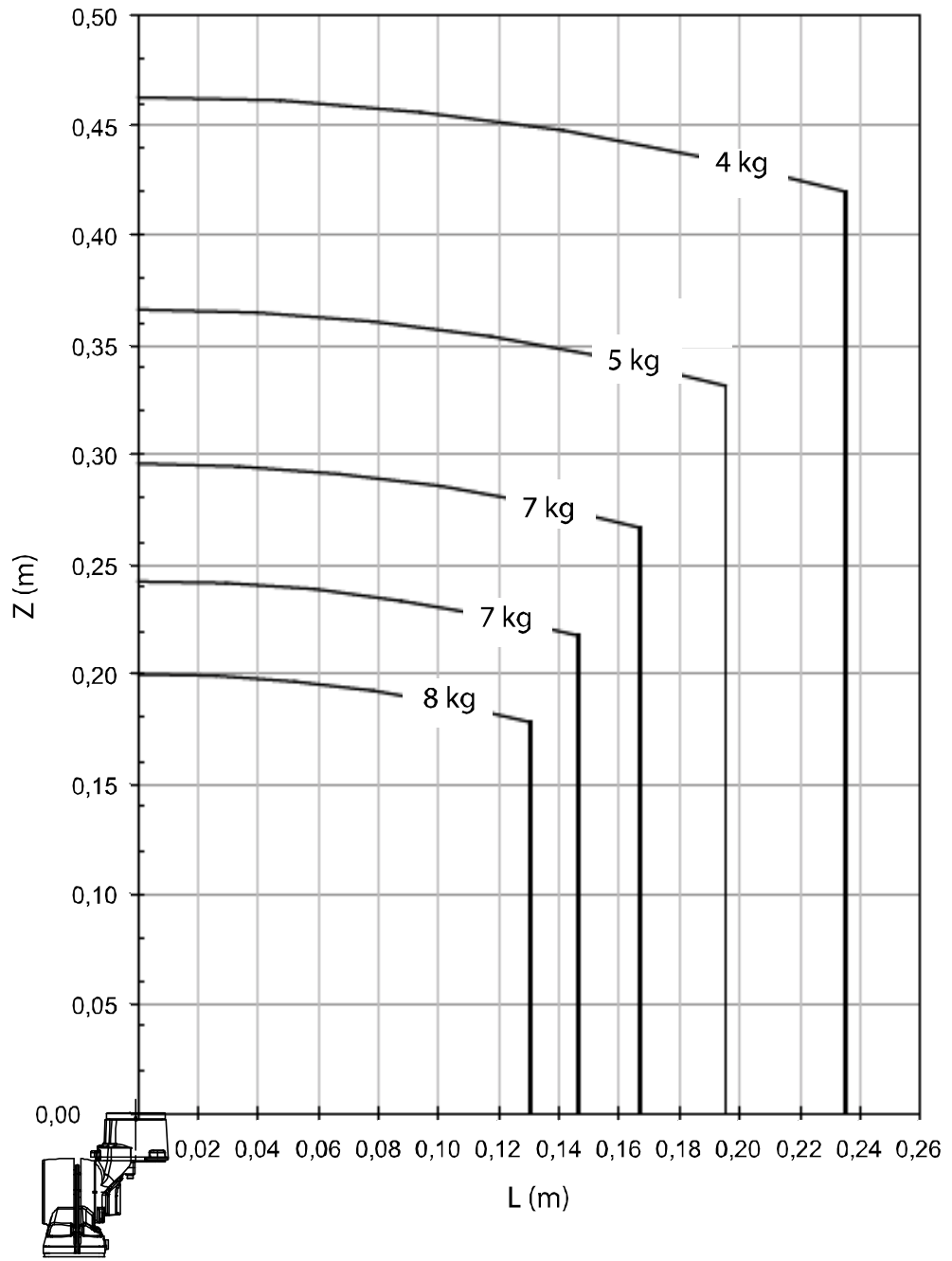

xx1000000967

Extra load of 15 kg at the upper arm housing and 1 kg at wrist included in the load diagram.

Continues on next page

IRB 2600ID-8/2.00 "Vertical Wrist" ($\pm 10^\circ$)

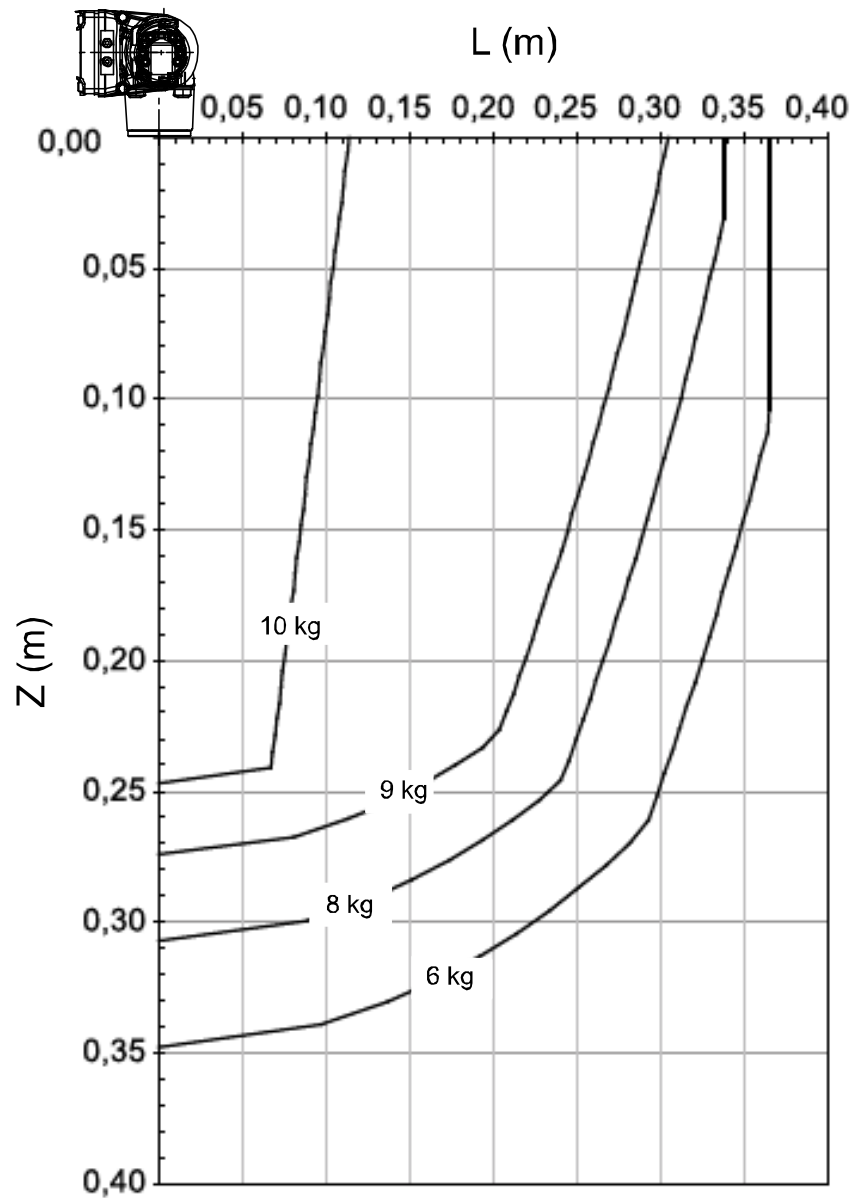

xx100000977

Extra load of 15 kg at upper arm and 1 kg at wrist included in the load diagram.
For wrist down $\pm 0^\circ$ deviation from the vertical line.

	Description
Max load	9.5 kg
Z _{max}	0.235 m
L _{max}	0.041 m

1 Description

1.5.3 Maximum load and moment of inertia for full and limited axis 5 (center line down) movement

1.5.3 Maximum load and moment of inertia for full and limited axis 5 (center line down) movement



Note

Total load given as: Mass in kg, center of gravity (Z and L) in meter and moment of inertia (J_{ox} J_{oy} J_{oz}) in kgm^2 . $L = \sqrt{x^2 + y^2}$.

Full movement of axis 5 ($\pm 120^\circ$)

Axis	Robot Type	Maximum moment of inertia
5	-20/1.65 -12/1.65 -12/1.85	$Ja5 = \text{Load} \times ((Z + 0,085)^2 + L^2) + \max(J_{0x}, J_{0y}) \leq 2.0 \text{ kgm}^2$
	ID-15/1.85	$Ja5 = \text{Load} \times ((Z + 0,135)^2 + L^2) + \max(J_{0x}, J_{0y}) \leq 2.0 \text{ kgm}^2$
	ID-8/2.00	$Ja5 = \text{Load} \times ((Z + 0,2)^2 + L^2) + \max(J_{0x}, J_{0y}) \leq 2.0 \text{ kgm}^2$
6	-20/1.65 -12/1.65 -12/1.85 ID-8/2.00 ID-15/1.85	$Ja6 = \text{Load} \times L^2 + J_{0z} \leq 1.0 \text{ kgm}^2$

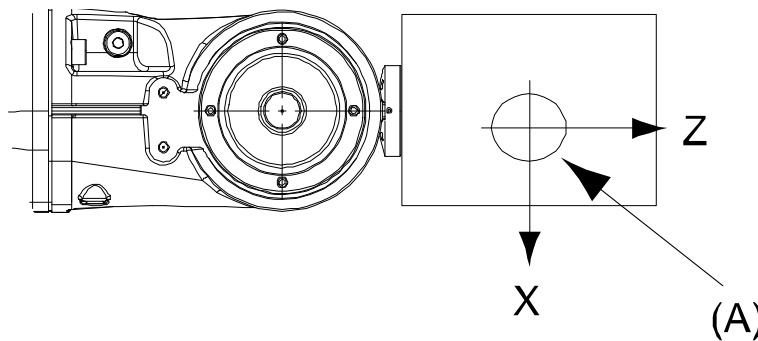

xx0800000458

Pos	Description
A	Center of gravity
Description	
J_{ox}, J_{oy}, J_{oz}	Max. moment of inertia around the X, Y and Z axes at center of gravity.

Continues on next page

1.5.3 Maximum load and moment of inertia for full and limited axis 5 (center line down) movement

Continued

Limited axis 5, center line down

Axis	Robot Type	Maximum moment of inertia
5	-20/1.65 -12/1.65 -12/1.85	$Ja5 = Load \times ((Z + 0,085)^2 + L^2) + \max (J_{0x}, J_{0y}) \leq 2.0 \text{ kgm}^2$
	ID-15/1.85	$Ja5 = Load \times ((Z + 0,135)^2 + L^2) + \max (J_{0x}, J_{0y}) \leq 2.0 \text{ kgm}^2$
	ID-8/2.00	$Ja5 = Load \times ((Z + 0,2)^2 + L^2) + \max (J_{0x}, J_{0y}) \leq 2.0 \text{ kgm}^2$
6	-20/1.65 -12/1.65 -12/1.85 ID-8/2.00 ID-15/1.85	$Ja6 = Load \times L^2 + J_{0z} \leq 1.0 \text{ kgm}^2$

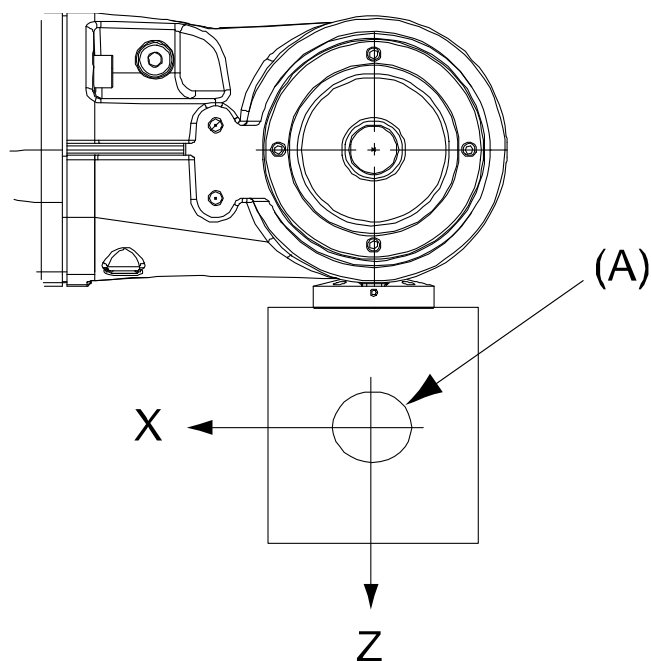

xx080000459

Pos	Description
A	Center of gravity
Description	
J_{0x}, J_{0y}, J_{0z}	Max. moment of inertia around the X, Y and Z axes at center of gravity.

1 Description

1.5.4 Wrist torque

1.5.4 Wrist torque

Maximum torque due to payload

The table below shows the maximum permissible torque due to payload:



Note

The values are for reference only, and should not be used for calculating permitted load offset (position of center of gravity) within the load diagram, since those also are limited by main axes torques as well as dynamic loads. Also arm loads will influence the permitted load diagram, please contact your local ABB organization.

Robot type	Max wrist torque axis 4 and 5	Max wrist torque axis 6	Max torque valid at load
IRB 2600-20/1.65	36.3 Nm	16.7 Nm	20 kg
IRB 2600-12/1.65 IRB 2600-12/1.85	21.8 Nm	10.0 Nm	12 kg
IRB 2600ID-15/1.85	34.6 Nm	11 Nm	15 kg
IRB 2600ID-8/2.00	31.4 Nm	10.2 Nm	8 kg

1.5.5 Maximum TCP acceleration

General

Higher values can be reached with lower loads than the nominal because of our dynamical motion control QuickMove2. For specific values in the unique customer cycle, or for robots not listed in the table below, we recommend then to use RobotStudio.

Maximum Cartesian design acceleration for nominal loads

Robot type	E-stop Max acceleration at nominal load COG [m/s ²]	Controlled Motion Max acceleration at nominal load COG [m/s ²]
IRB 2600-20/1.65	94	51
IRB 2600-12/1.85	105	68
IRB 2600ID-15/1.85	104	59
IRB 2600ID-8/2.0	134	89



Note

Acceleration levels for E-stop and controlled motion includes acceleration due to gravitational forces. Nominal load is define with nominal mass and cog with max offset in Z and L (see load diagram).

1 Description

1.6.1 Information about mounting equipment

1.6 Mounting equipment

1.6.1 Information about mounting equipment

General

Extra loads can be mounted on the wrist, the upper arm housing and on the frame. Definitions of load areas and permitted load are shown in. The center of gravity of the extra load shall be within the marked load areas. The robot is supplied with holes for mounting of extra equipment. (See figures in Holes for mounting of extra equipment.)

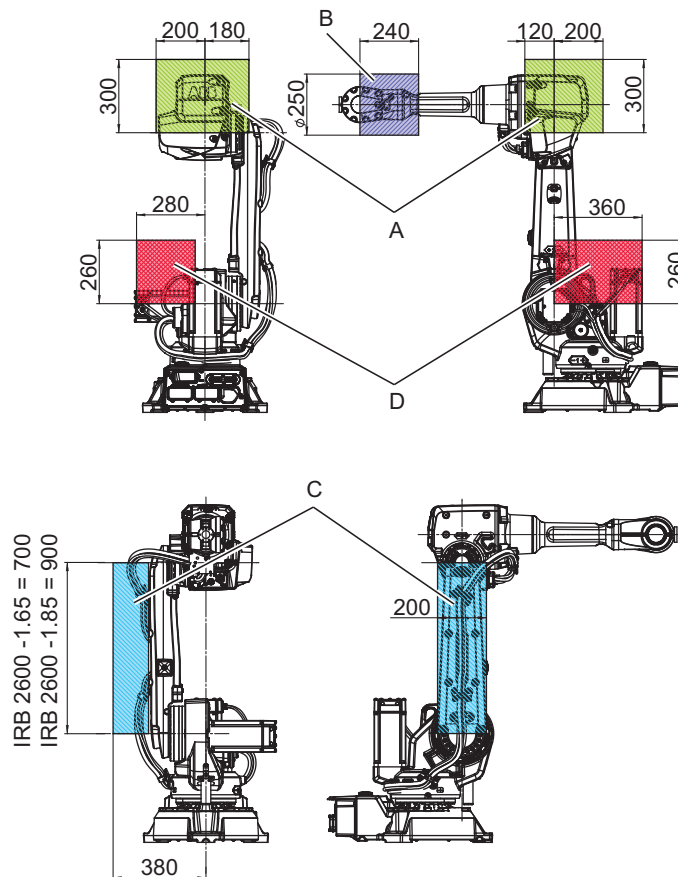

xx0900000189

Load area robot	Max load				
	A	B	C	A+C	D
IRB 2600-20/1.65 IRB 2600 - 12/1.85	10 kg	1 kg	10 kg	10 kg	35 kg
IRB 2600-12/1.65	15 kg	1 kg	15 kg	15 kg	35 kg

Continues on next page

1 Description

1.6.1 Information about mounting equipment

Continued

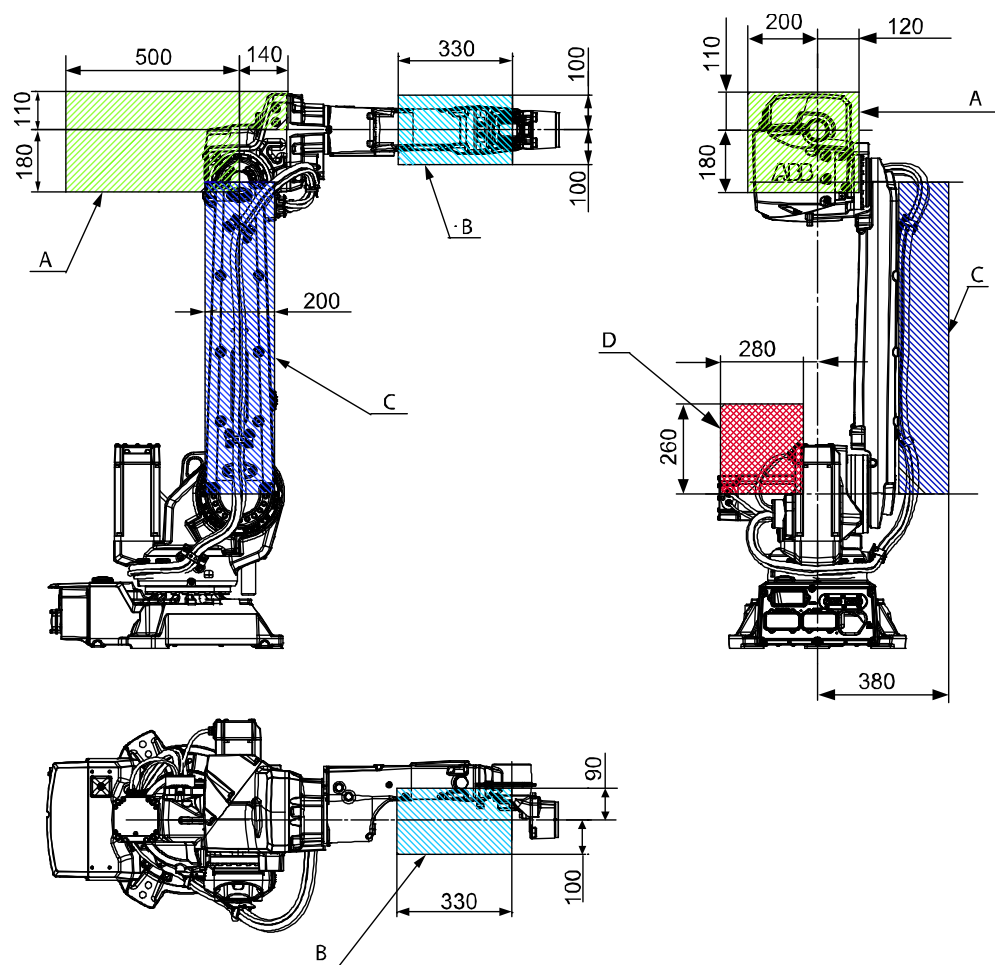

xx1000000978

Load area robot	Max load				
	A	B	C	A+C	D
IRB 2600ID-15/1.85	10 kg	1 kg	10 kg	10 kg	35 kg
IRB 2600ID-8/2.00	10 kg	1 kg	10 kg	15 kg	35 kg



Note

Maximum loads must never be exceeded!

Continues on next page

1 Description

1.6.1 Information about mounting equipment

Continued

Holes for mounting of extra equipment

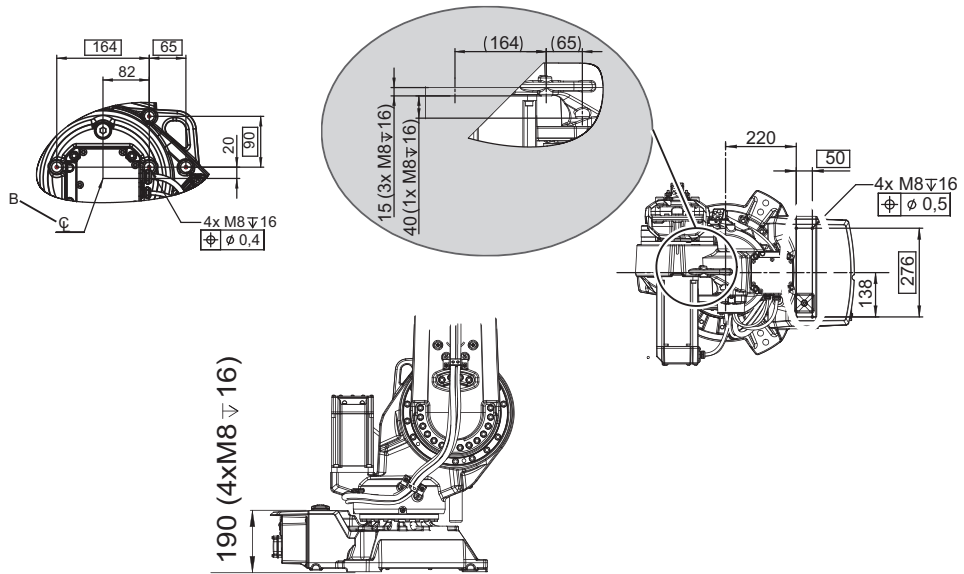

xx0900000484

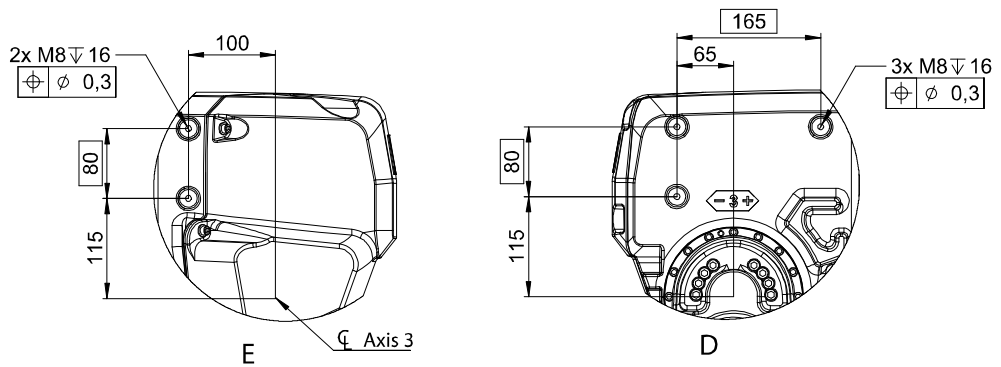

xx0900000485

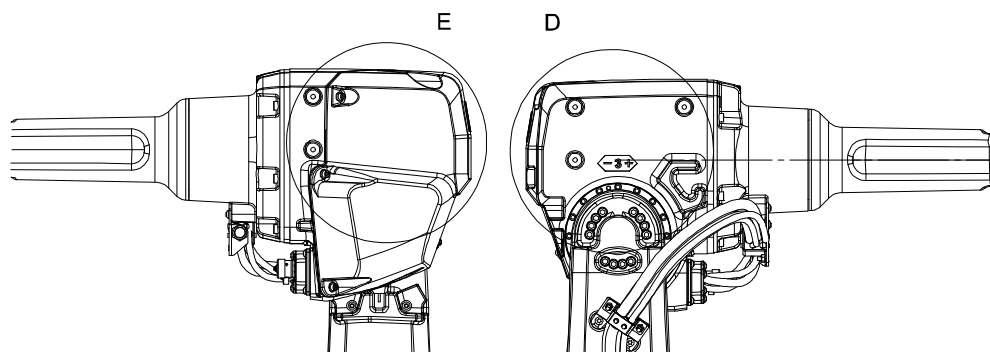

xx0900000486

Continues on next page

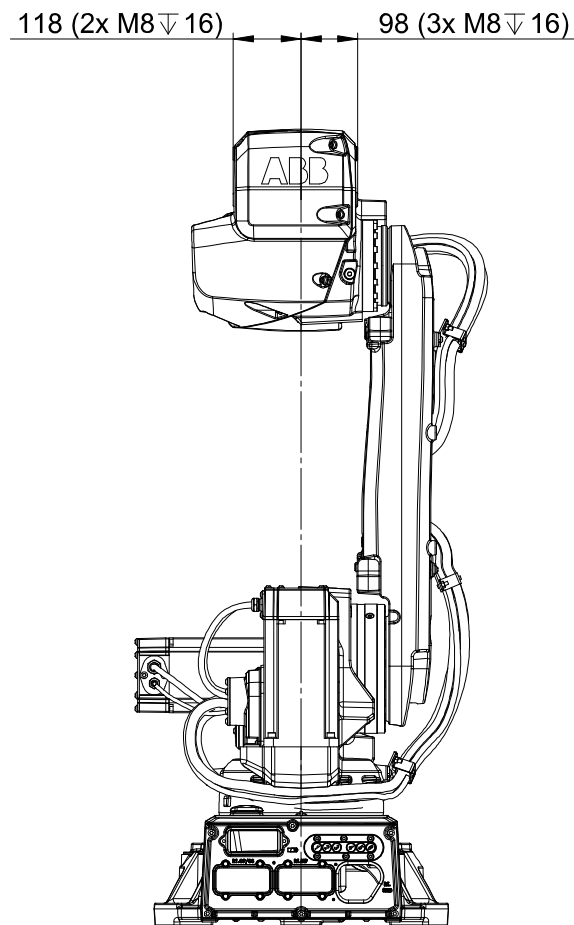

1 Description

1.6.1 Information about mounting equipment

Continued

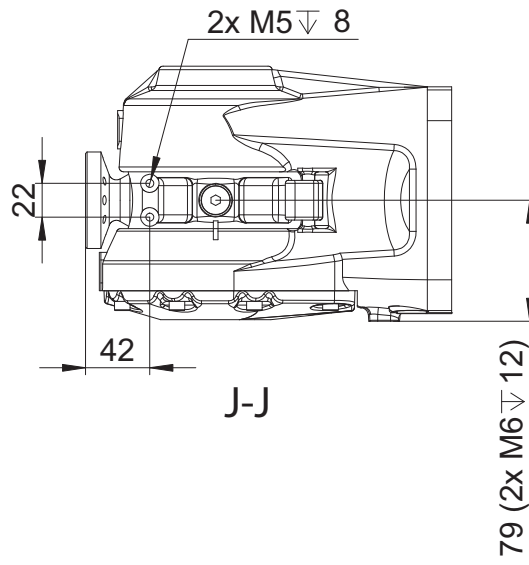

xx0900000489

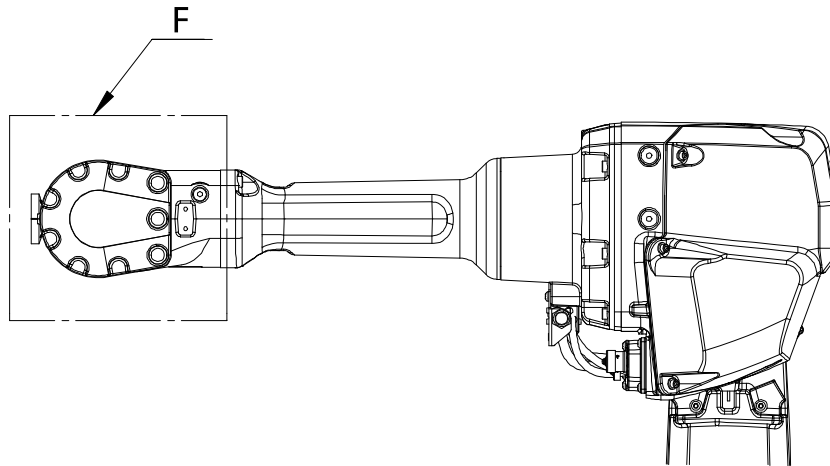

xx0900000490

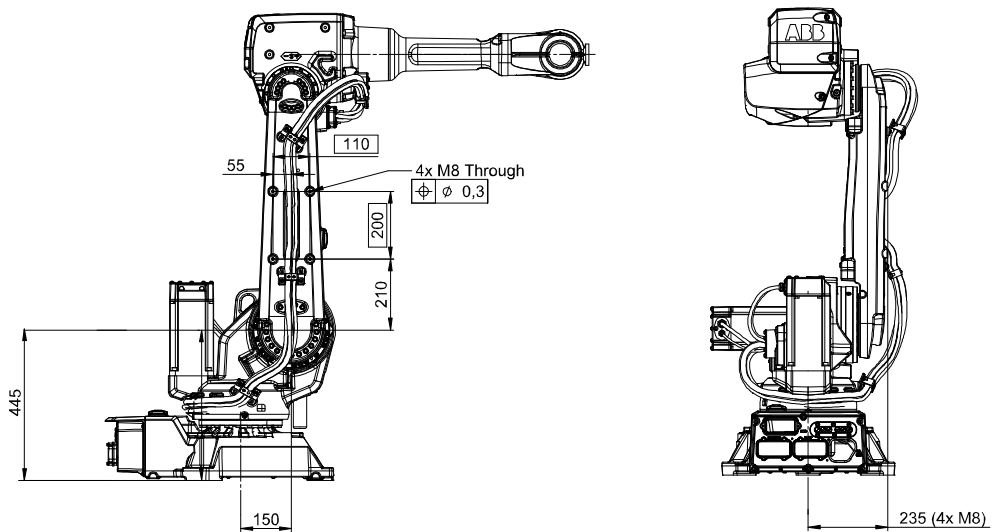

xx0900000491

Continues on next page

1 Description

1.6.1 Information about mounting equipment

Continued

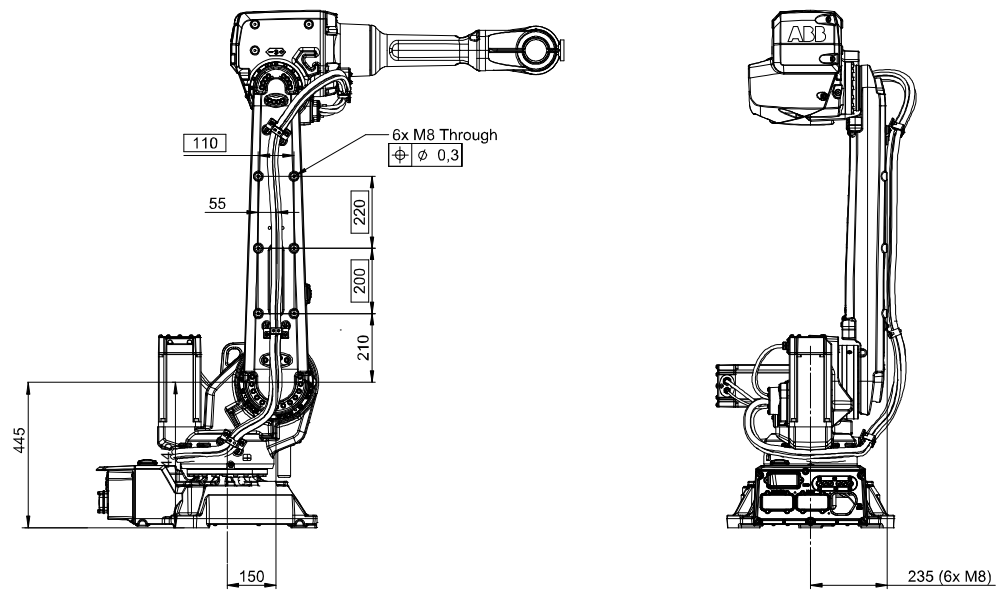

xx0900000492

Continues on next page

1 Description

1.6.1 Information about mounting equipment

Continued

Holes for mounting of extra equipment for IRB 2600ID

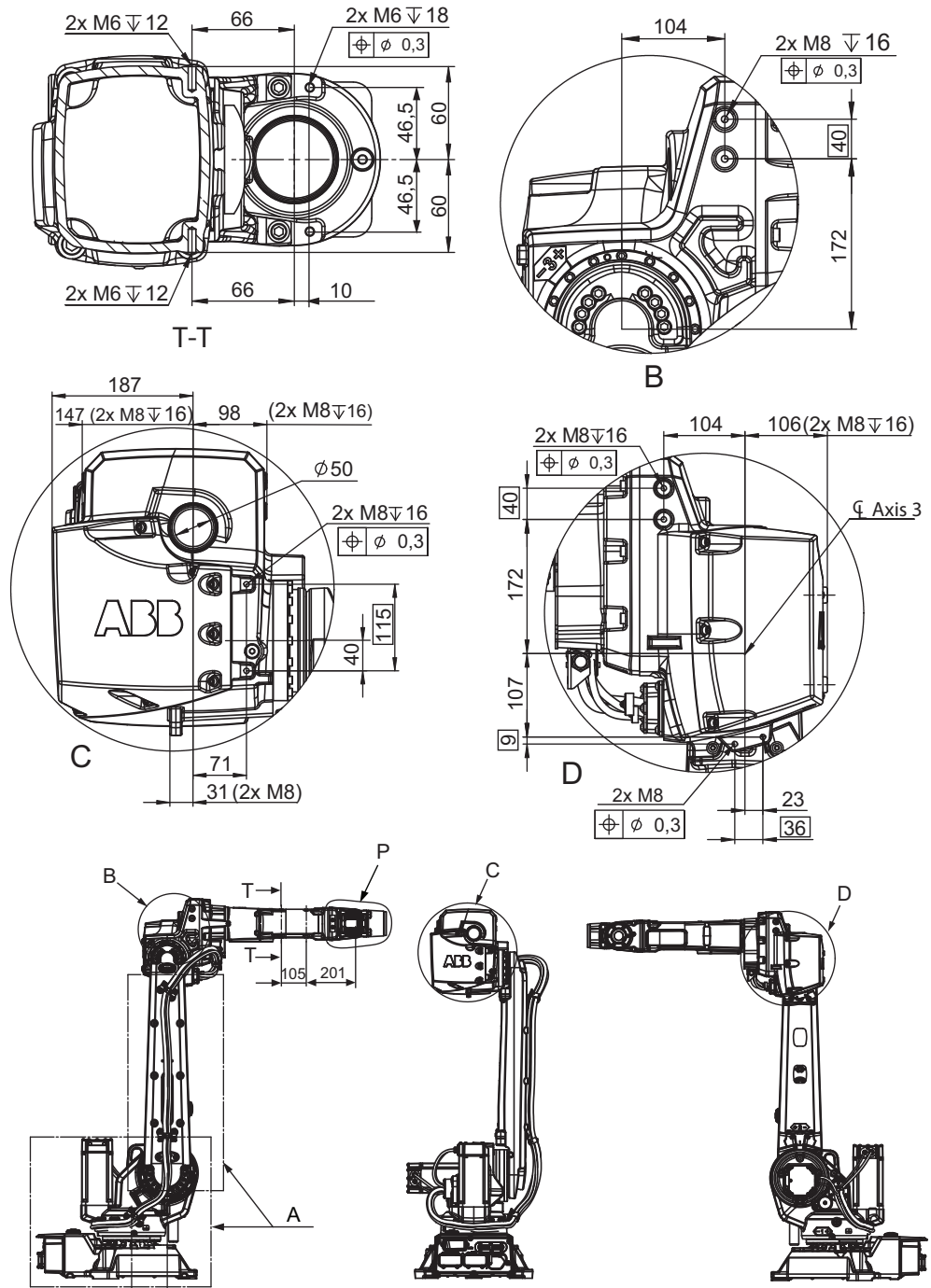

xx1000000968

Pos	Description
A	See IRB 2600 standard robot for details.

Continues on next page

Tool flange IRB 2600

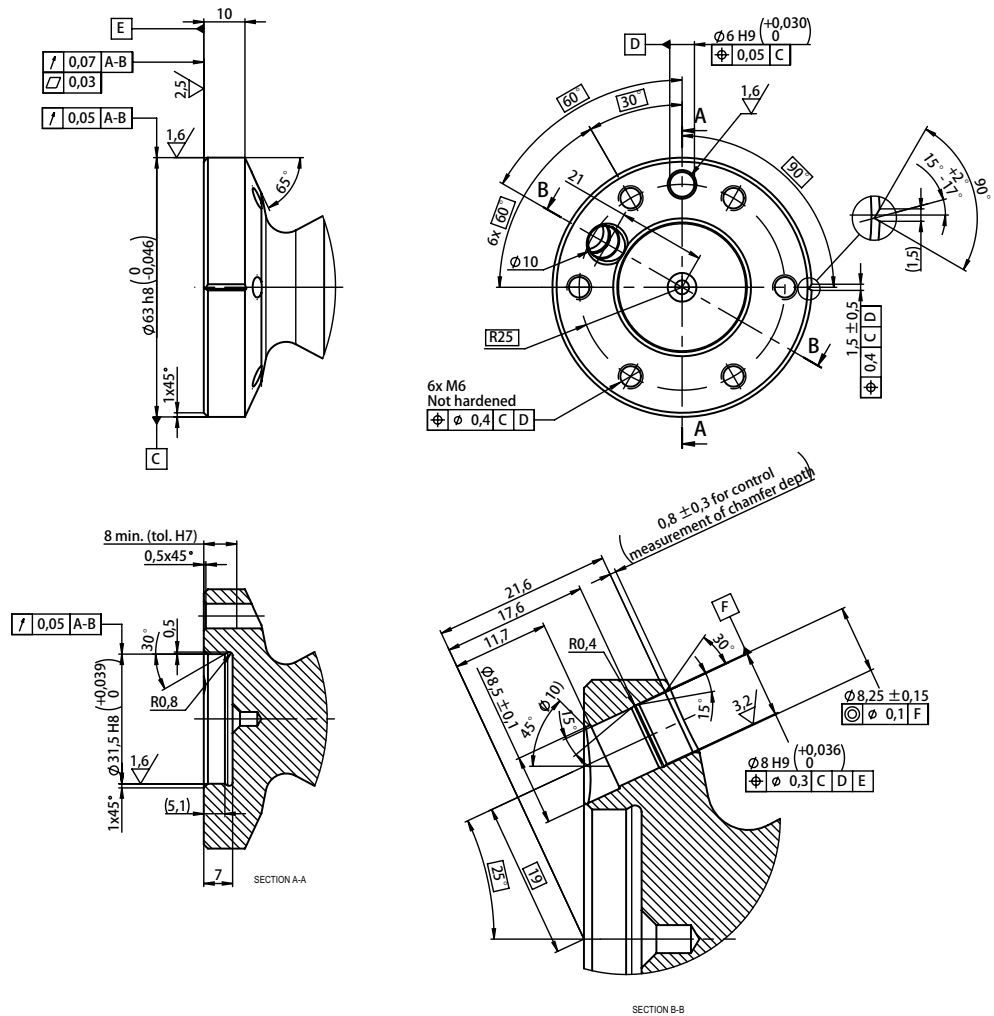

xx0800000449

For fastening of gripper tool flange to Robot tool flange every one of the screw holes for 6 screws, quality class 12.9 shall be used. Min. 10 mm used thread length.

Continues on next page

1 Description

1.6.1 Information about mounting equipment

Continued

Tool flange/wrist for IRB 2600ID

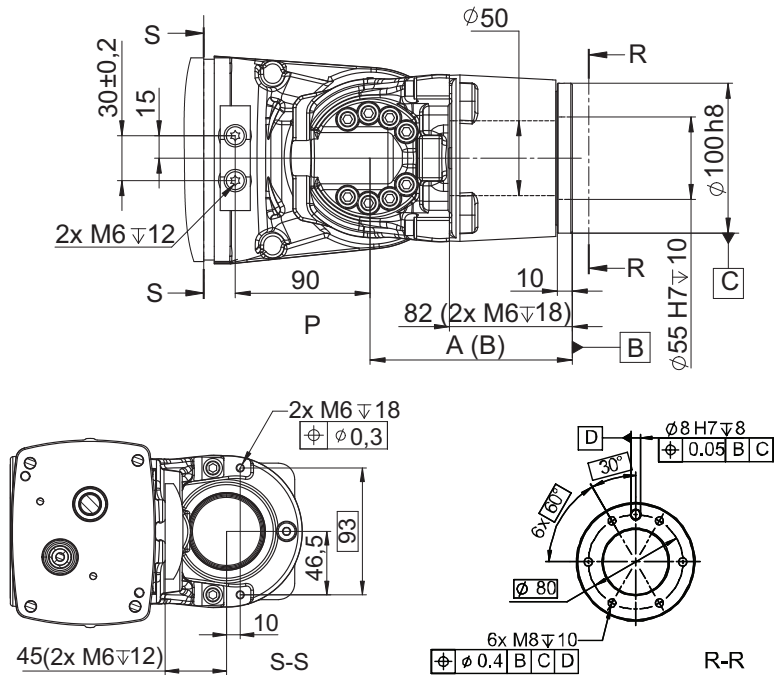
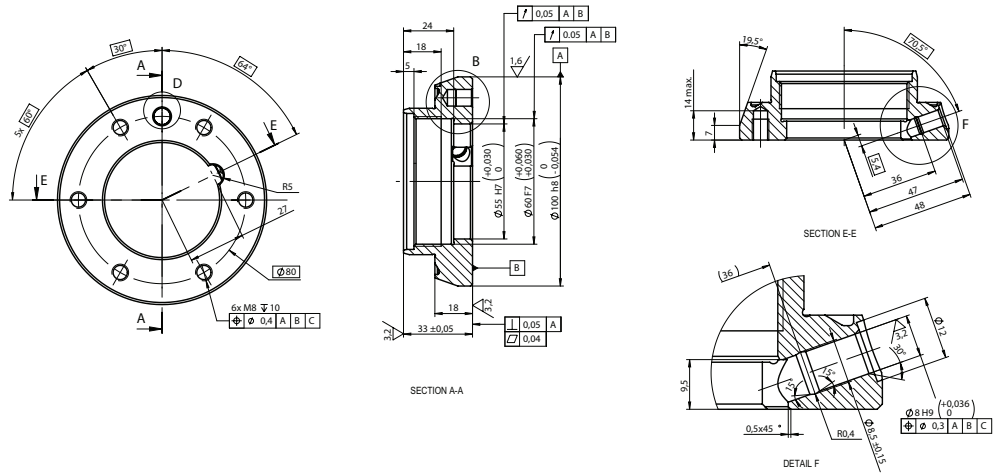

xx100000969

Pos	Description
A	135 mm for IRB 2600ID-15/1.85
B	200 mm for IRB 2600ID-8/2.00

For fastening of gripper tool flange to Robot tool flange every other one of the screw holes for 6 screws, quality class 12.9 shall be used.

1.7 Maintenance and Troubleshooting

1.7.1 Introduction to Maintenance and Troubleshooting

General

The robot requires only minimum maintenance during operation. It has been designed to make it as easy to service as possible:

- Maintenance-free AC motors are used.
- Oil is used for the gear boxes.
- The cabling is routed for longevity, and in the unlikely event of a failure, its modular design makes it easy to change.

Maintenance

The maintenance intervals depend on the use of the robot, the required maintenance activities also depends on selected options. For detailed information on maintenance procedures, see Maintenance section in the Product Manual.

1 Description

1.8.1 Introduction to Robot Motion

1.8 Robot Motion

1.8.1 Introduction to Robot Motion

IRB 2600

Axis	Type of motion	Range of movement
1	Rotation motion	+ 180° to - 180° ⁱ
2	Arm motion	+ 155° to - 95°
3	Arm motion	+ 75° to - 180°
4	Rotation motion	+ 400° to - 400° + 251 rev. to - 251 rev. Max.
5	Bend motion	+ 120° to - 120°
6	Turn motion	+ 400° to - 400° + 274 rev. to - 274 rev. Max.

ⁱ See [Limitations for wall mounted robots on page 60](#)

For verifying each load case, please contact your local ABB organization.

The default working range for axis 4 and axis 6 can be extended by changing system parameter values in the software. Option 610 - *Independent axis* can be used for resetting the revolution counter after the axis has been rotated (no need for "rewinding" the axis).

Limitations for wall mounted robots

The axis 1 working range has the following limitations for wall mounted robots:

Robot variant	Max payload (kg)	Max arm-load (kg)	Working range axis 1, with max payload + max arm load	Max combined pay/arm-load (kg) for ±180° working range axis 1
IRB 2600-20/1.65	20	11	±45°	8
IRB 2600-12/1.65	12	16	±45°	8
IRB 2600-12/1.85	12	11	±40°	-

IRB 2600ID

Axis	Type of motion	Range of movements
1	Rotation motion	+ 180° to - 180° ⁱ
2	Arm motion	+ 155° to - 95°
3	Arm motion	+ 75° to - 180°
4	Rotation motion	+ 175° to - 175°
5	Bend motion	+ 120° to - 120°
6	Turn motion	+ 400° to - 400° + 191 rev. to - 191 rev. Max.

ⁱ See [Limitations for tilt and wall mounted robots on page 61](#)

Continues on next page

Limitations for tilt and wall mounted robots

The axis 1 working range has the following limitation for tilt and wall mounting.

Mounting position	Description
Max tilting angle for full axis 1 working range	40 degrees
Max working range for axis 1 at wall mounting	± 40 degrees

Working range

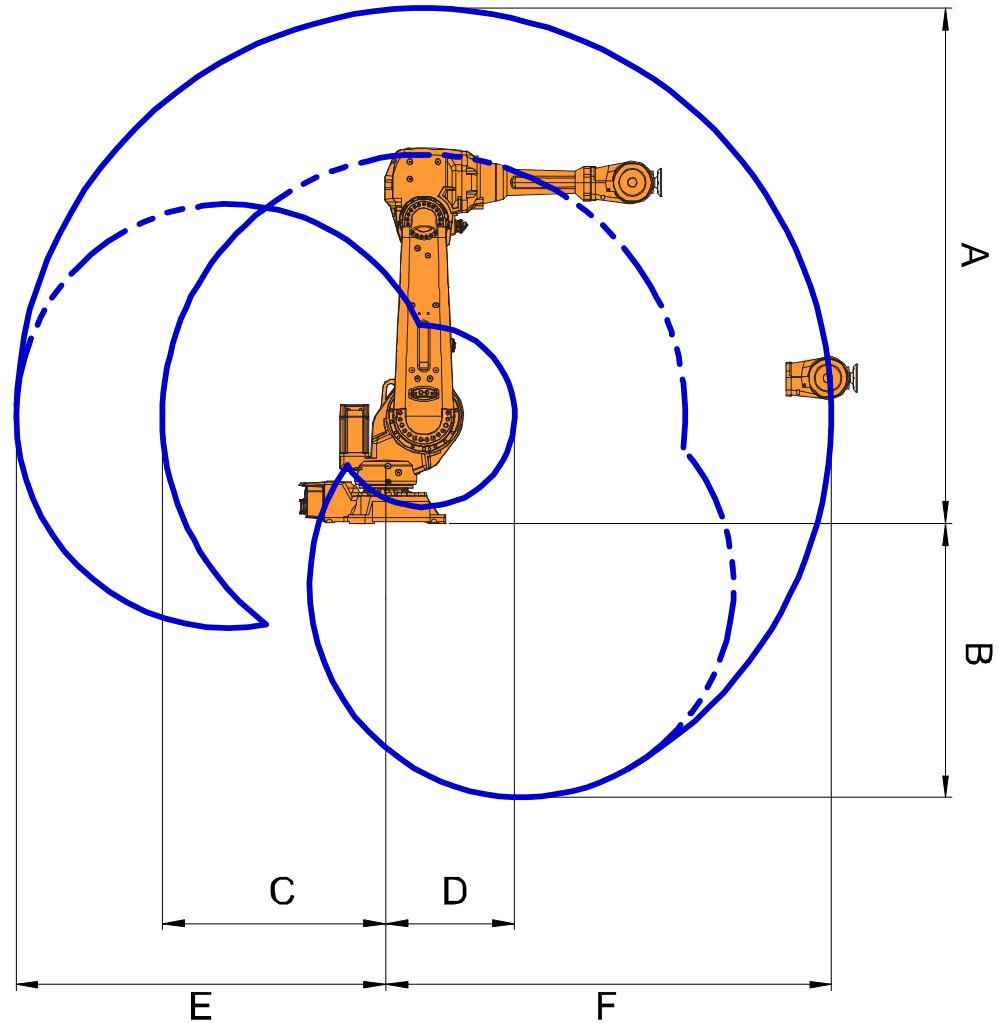

xx080000267

Variant	Pos. A	Pos. B	Pos. C	Pos. D	Pos. E	Pos. F
IRB 2600-20/1.65	1948 mm	993 mm	837 mm	469 mm	1353 mm	1653 mm
IRB 2600-12/1.65						
IRB 2600-12/1.85	2148 mm	1174 mm	967 mm	506 mm	1553 mm	1853 mm

Continues on next page

1 Description

1.8.1 Introduction to Robot Motion

Continued

Working range IRB 2600ID

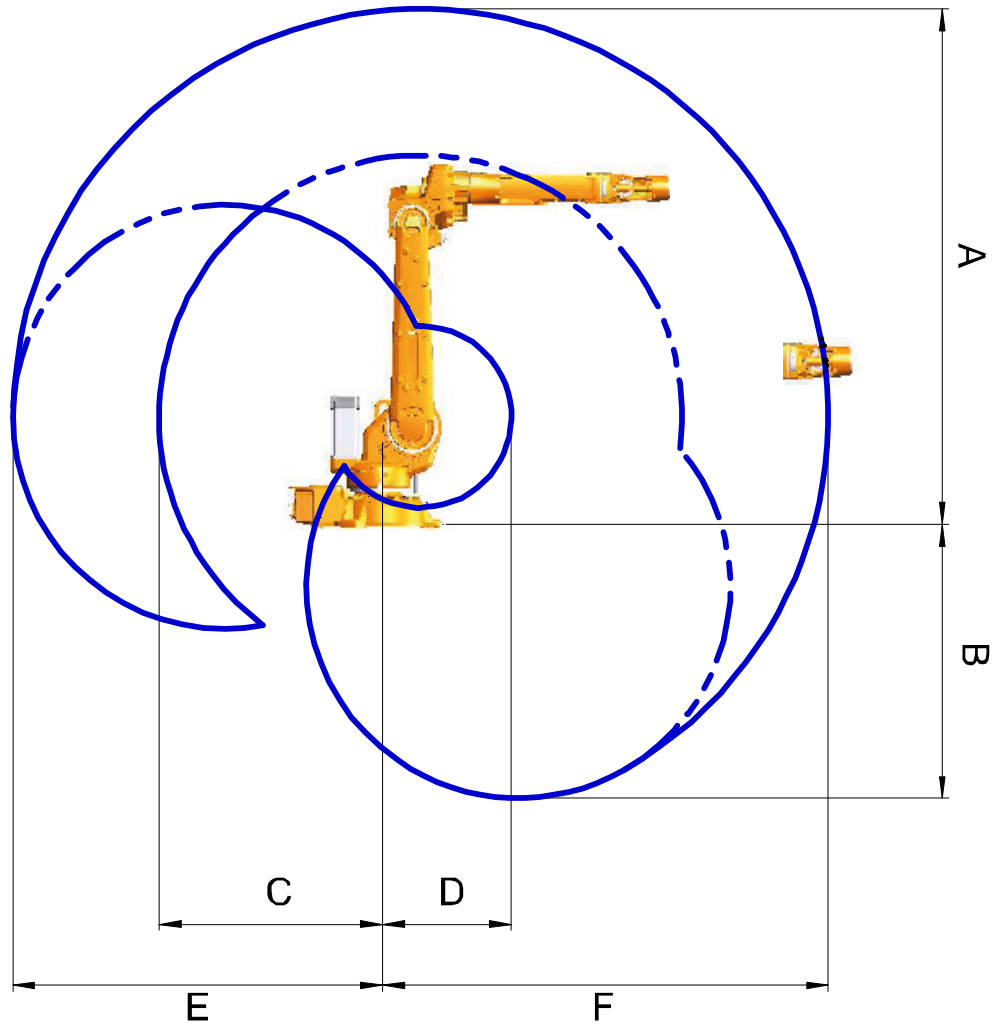

xx100000970

Variant	Pos. A	Pos. B	Pos. C	Pos. D	Pos. E	Pos. F
IRB 2600ID-15/1.85	2145 mm	1171 mm	936 mm	542 mm	1550 mm	1850 mm
IRB 2600ID-8/2.00	2295 mm	1321 mm	1051 mm	539 mm	1700 mm	2000 mm

1.8.2 Performance according to ISO 9283

General

At rated maximum load, maximum offset and 1.6 m/s velocity on the inclined ISO test plane, with all six axes in motion. Values in the table below are the average result of measurements on a small number of robots. The result may differ depending on where in the working range the robot is positioning, velocity, arm configuration, from which direction the position is approached, the load direction of the arm system. Backlashes in gearboxes also affect the result.

The figures for AP, RP, AT and RT are measured according to figure below.

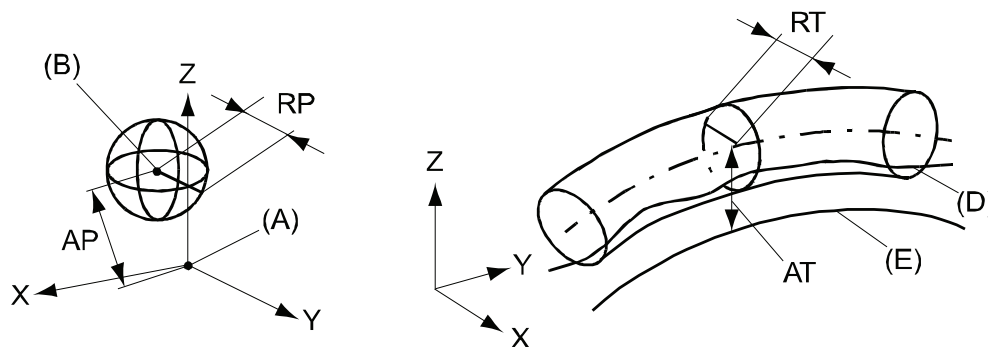

xx080000424

Pos	Description	Pos	Description
A	Programmed position	E	Programmed path
B	Mean position at program execution	D	Actual path at program execution
AP	Mean distance from programmed position	AT	Max deviation from E to average path
RP	Tolerance of position B at repeated positioning	RT	Tolerance of the path at repeated program execution

Description	IRB 2600			IRB 2600ID	
	-20/1.65	-12/1.65	-12/1.85	-15/1.85	-8/2.00
Pose repeatability, RP (mm)	0.04	0.04	0.04	0.026	0.023
Pose accuracy, AP ⁱ (mm)	0.03	0.03	0.03	0.014	0.033
Linear path repeatability, RT (mm)	0,13	0.14	0,16	0.30	0.27
Linear path accuracy, AT (mm)	0.55	0.60	0.68	0.80	0.70
Pose stabilization time, (PSt) to within 0.2 mm of the position (s)	0.00	0.02	0.03	0.05	0.063

ⁱ AP according to the ISO test above, is the difference between the reached position (position manually modified in the cell) and the average position obtained during program execution.

1 Description

1.8.3 Velocity

1.8.3 Velocity

Maximum axis speed

Robot type	Axis 1	Axis 2	Axis 3	Axis 4	Axis 5	Axis 6
IRB 2600-20/1.65	175 °/s	175 °/s	175 °/s	360 °/s	360 °/s	500 °/s
IRB 2600-12/1.65	175 °/s	175 °/s	175 °/s	360 °/s	360 °/s	500 °/s
IRB 2600-12/1.85	175 °/s	175 °/s	175 °/s	360 °/s	360 °/s	500 °/s
IRB 2600ID-15/1.85	175 °/s	175 °/s	175 °/s	360 °/s	360 °/s	500 °/s
IRB 2600ID-8/2.00	175 °/s	175 °/s	175 °/s	360 °/s	360 °/s	500 °/s

There is a supervision function to prevent overheating in applications with intensive and frequent movements.

Axis resolution

0.001° to 0.005°.

1.8.4 Robot stopping distances and times

Introduction

The stopping distances and times for category 0 and category 1 stops, as required by EN ISO 10218-1 Annex B, are listed in *Product specification - Robot stopping distances according to ISO 10218-1 (3HAC048645-001)*.

1 Description

1.9 Cooling fan for axis 1-2 motor

1.9 Cooling fan for axis 1-2 motor

Option 87-1, 88-1

To be used to avoid overheating of motors and gears in applications with intensive motion (high average speed and /or high average torque and/or short wait time) of axis 1 and/or axis 2.

Valid protection for cooling fan is IP54. Fan failure stops the robot.

To determine the use of cooling fans for axis 1 and/or axis 2 motor use the “Gearbox Heat Prediction Tool” in RobotStudio. Reliable facts for the decision of need for fan or not will be achieved by entering the ambient temperature for a specific cycle. Please contact your local ABB organization.

1.10 Customer connections

1.10.1 Introduction

General

Customer connections are options, the cables for them are integrated in the robot and the connectors are placed on the upper arm housing and at the base. One UT0W71210SH06 connector (R2.CP(ETHERNET)) and one UT0W71626H06 connector (R2.CS(/CP)). Corresponding connectors, R1.CP(/R1.ETHERNET) and R1.CS(/CP) are located at the base. Hose for compressed air is also integrated into the manipulator. There is an (M16-3/8" hose) inlet at the base and an outlet on the rear part of the upper arm.

Customer connections

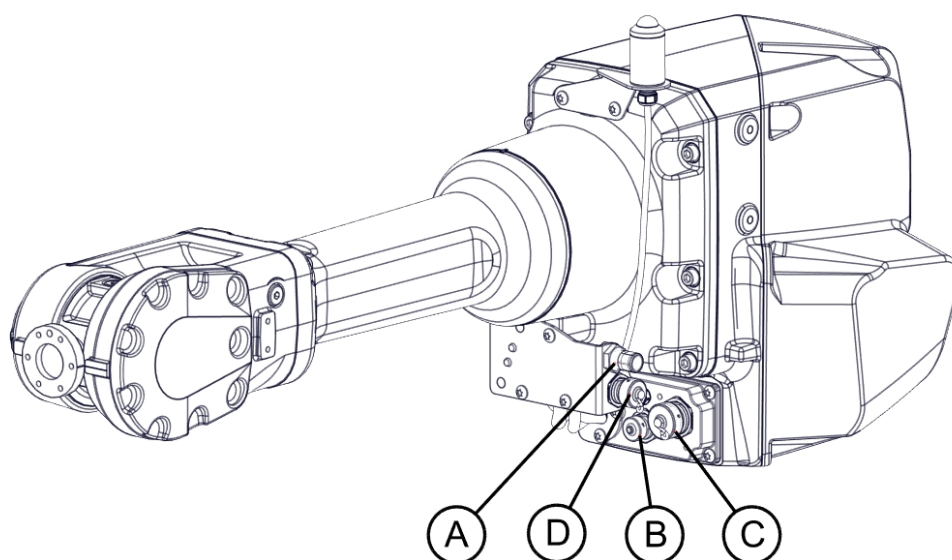

xx1700002239

Pos	Connection	Description	Quantity	Value
A	Air M16x1.5	max 8 bar	1	Inner hose diameter 9.5 mm
B	R2.CP	Customer power	4 ⁱ	300 V, 2 A
C	R2.CS	Customer signals	23	50 V, 0.5 A
D	R2.ETHERNET	Multibus comm		PROFINET, EtherNet/IP DeviceNet PROFIBUS

ⁱ One protected ground is included.

Continues on next page

1 Description

1.10.1 Introduction

Continued

Customer connections base

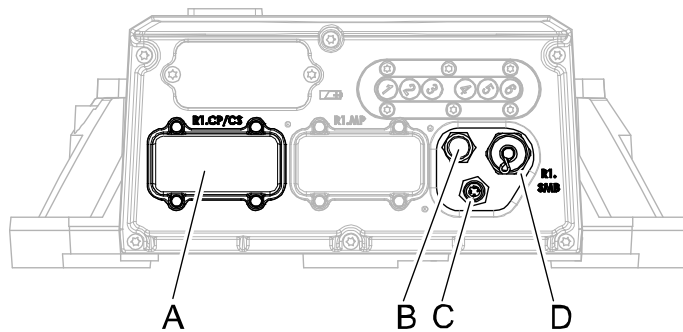

xx0800000288

A	R1.CP/CS
B	Air M16x1.5
C	R1.ETHERNET
D	R1.SMB

2 Specification of variants and options

2.1 Introduction to variants and options

General

The different variants and options for the IRB 2600/IRB 2600 ID are described in the following sections. The same option numbers are used here as in the specification form.

The variants and options related to the robot controller are described in the product specification for the controller.

2 Specification of variants and options

2.2 Manipulator

2.2 Manipulator

Variants

Option	IRB Type	Handling capacity (kg) / Reach (m)
435-95	IRB 2600	20/1.65
435-96	IRB 2600	12/1.65
435-97	IRB 2600	12/1.85
435-103	IRB 2600ID	15/1.85
435-104	IRB 2600ID	8/2.00

Manipulator color

Option	Description	Note
209-1	ABB Orange standard	
209-2	ABB White standard	
209-202	ABB Graphite White standard	Standard color
209-4 -192	The manipulator is painted with the chosen RAL-color.	



Note

Notice that delivery time for painted spare parts will increase for none standard colors.

Protection types

Option	Protection type	Note
287-4	Standard	IRB 2600: IP 67 IRB 2600ID upper arm: IP 54
287-3	Foundry Plus 2	See Protection type Foundry Plus 2 on page 11 for a complete description of protection type Foundry Plus 2. Not valid for IRB 2600ID versions.

Mounting position

Option	Description
224-2	Inverted mounting of the manipulator Not together with option 603-1 Absolute Accuracy.



Note

Manipulators delivered for floor mounting must have the option added before changing mounting position to inverted.

Continues on next page

Media & Communication

Air supply and signals for extra equipment upper arm, see 1.9 Customer connections.

Option	Type	Description
803-1	Parallel communication and air	Includes customer power CP and customer signals CS + air.
803-2	Ethernet, parallel communication and air	Includes CP, CS and PROFINET or Ethernet/IP + air.
803-3	DeviceNet, parallel communication and air	Includes CP, CS and DeviceNet + air
803-4	PROFIBUS	Includes CP, CS and PROFIBUS + air

Connector kit

The kit consists of connectors, pins and sockets:

Option	Description
431-1	For the connectors on the upper arm.
239-1	For the connectors on the foot if connection to manipulator.

Flexible conduit

Protection hose for customer signals, power and hoses. Only valid for IRB 2600ID.

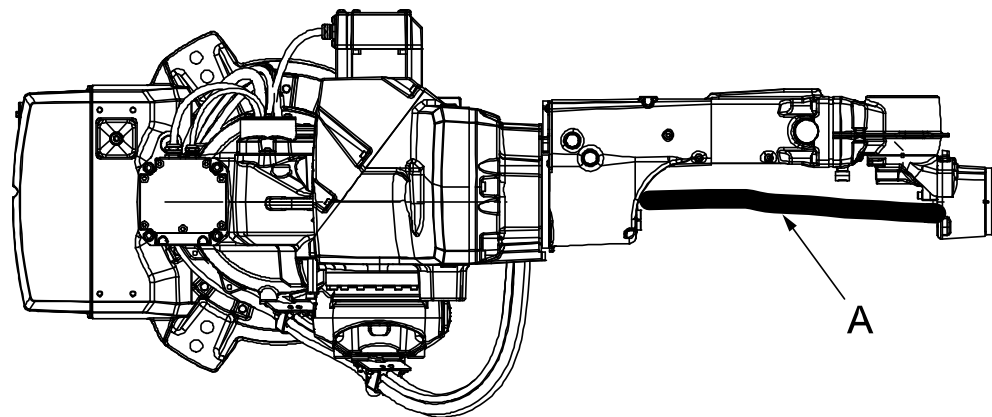

xx100000982

Pos	Description
A	Flexible conduit, option 943-1.

Safety lamp

Option	Description
213-1	Safety lamp safety lamp with an orange fixed light can be mounted on the manipulator. The lamp is active in MOTORS ON mode. The safety lamp is required on a UL/UR approved robot.

Continues on next page

2 Specification of variants and options

2.2 Manipulator

Continued

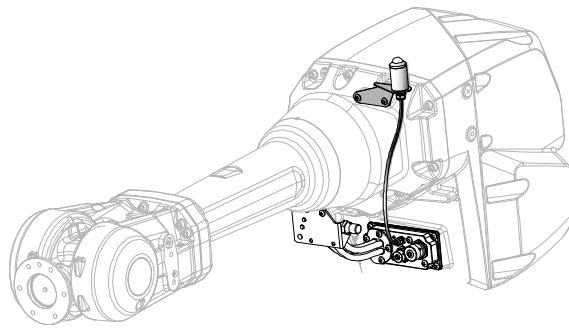

xx0800000427

Cooling fans for axis 1 and 2 motor

To be used to avoid overheating of motors and gears in application with intensive motion (high average speed and/or high average torque and/or short wait time) of axis 1 and axis 2. IP54 valid for cooling fan.

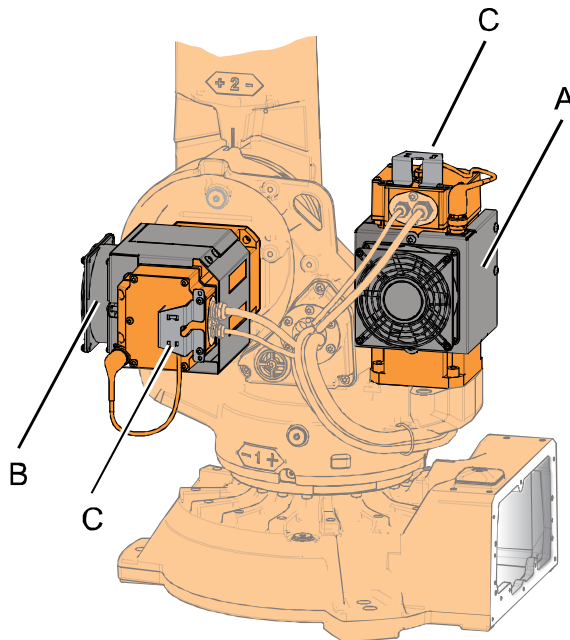

xx0900000232

Option	Description
A	Cooling fan for axis 1 motor, option 87-1.
B	Cooling fan for axis 2 motor, option 88-1.
C	Protection cover

Resolver connection, axis 7

A connector for resolver signals for axis 7 located on the base

Option	Description	Remark
864-1	On base	Used together with first additional drive, option 907-1.

Continues on next page

Foundry Plus Cable Guard

The manipulator cables are equipped with an additional protection of aluminized leather against e.g. aluminium spitz and flashes and chips from machining.

Option	Type	Description
908-1	Foundry Plus Cable Guard	For extra protection of cables. Requires option 287-3 Foundry Plus.

Electronic Position Switches (EPS)

The mechanical position switches indicating the position of the three main axes are replaced with electronic position switches for up to 7 axes, for increased flexibility and robustness. For more detailed information, see *Product specification - Controller IRC5* and *Application manual - Electronic Position Switches*.

Working range limit-Axis 1

The working range of axis 1 is limited by fixed mechanical stops. The working range can be reduced further by adding movable mechanical stops.

The mechanical turning range can be limited in steps of 22.5° from the synchronization position, between values defined in the table. The values differ depending on which design of the gearbox (and base) the robot is equipped with.

Robot variant	Limitation in mechanical turning range, calculated from synchronization position
IRB 2600-20/1.65, IRB 2600-12/1.65, IRB 2600-12/1.85, IRB 2600ID-15/1.85, IRB 2600ID-8/2.0	±129° to ±16.5° in steps of 22.5°



Note

The software working range limitations must be adjusted to correspond to the changes in the mechanical limitations of the working range. The system parameters that must be changed (*Upper joint bound* and *Lower joint bound*) are described in *Technical reference manual - System parameters*.

Option	Description
28-1 Axis 1	Two stops for restricting the working range. The stops can be mounted according to example in.

Continues on next page

2 Specification of variants and options

2.2 Manipulator

Continued

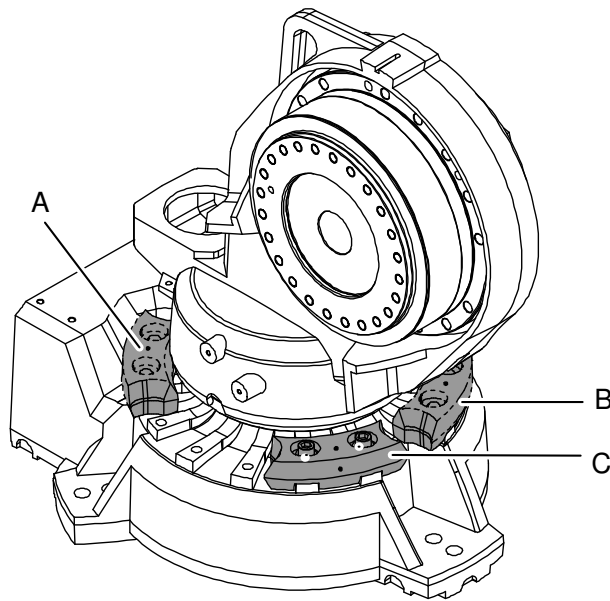

xx080000410

Pos	Description
A	Movable mechanical stop. Limited to: <ul style="list-style-type: none"> -129°
B	Movable mechanical stop. Limited to: <ul style="list-style-type: none"> +16.5°
C	Movable mechanical stop. Limited to: <ul style="list-style-type: none"> -16.5°

Warranty

Option	Type	Description
438-1	Standard warranty	Standard warranty is 12 months from <i>Customer Delivery Date</i> or latest 18 months after <i>Factory Shipment Date</i> , whichever occurs first. Warranty terms and conditions apply.
438-2	Standard warranty + 12 months	Standard warranty extended with 12 months from end date of the standard warranty. Warranty terms and conditions apply. Contact Customer Service in case of other requirements.
438-4	Standard warranty + 18 months	Standard warranty extended with 18 months from end date of the standard warranty. Warranty terms and conditions apply. Contact Customer Service in case of other requirements.
438-5	Standard warranty + 24 months	Standard warranty extended with 24 months from end date of the standard warranty. Warranty terms and conditions apply. Contact Customer Service in case of other requirements.
438-6	Standard warranty + 6 months	Standard warranty extended with 6 months from end date of the standard warranty. Warranty terms and conditions apply.
438-7	Standard warranty + 30 months	Standard warranty extended with 30 months from end date of the standard warranty. Warranty terms and conditions apply.

Continues on next page

Option	Type	Description
438-8	Stock warranty	<p>Maximum 6 months postponed start of standard warranty, starting from factory shipment date. Note that no claims will be accepted for warranties that occurred before the end of stock warranty. Standard warranty commences automatically after 6 months from <i>Factory Shipment Date</i> or from activation date of standard warranty in WebConfig.</p> <p> Note</p> <p>Special conditions are applicable, see <i>Robotics Warranty Directives</i>.</p>

2 Specification of variants and options

2.3 Positioners

2.3 Positioners

General

Regarding positioners, see *Product specification - IRBP /D2009, 3HAC038208-001*.

2.4 Floor cables

Manipulator cable length

Option	Lengths (m)
210-2	7
210-3	15
210-4	22
210-5	30

Application interface connection

Option	Name	Description
16-1	Cabinet	The signals are connected to 12-pole screw terminals, Phoenix MSTB 2.5/12-ST-5.08, to the Control Module.

Connection of Parallel/CAN DeviceNet communication

Following information specifies the cable length for Parallel/CAN DeviceNet/Ethernet + PROFIBUS floor cables for connections between cabinets and manipulator.

Option	Lengths (m)
94-1/90-2/859-1/92-2	7
94-2/90-3/859-2/92-3	15
90-4/859-3/92-4	22
94-4/90-5/859-4/92-5	30

2 Specification of variants and options

2.5 DressPack

2.5 DressPack

Process module

Option	Type	Description
768-1	Empty cabinet small	See <i>Product specification - Controller IRC5 with FlexPendant</i> , list of variants
768-2	Empty cabinet large	See <i>Product specification - Controller IRC5 with FlexPendant</i> , list of variants

WeldGuide III

Option	Type	Description
958-1	Basic	Only together with ArsitoMig 4000i/5000i, MigRob and TPS power sources. Digital I/O or AD Combi I/O is needed for WeldGuide functions. Requires option WeldGuide MultiPass [815-2].
958-2	Advanced	Only together with ArsitoMig 4000i/5000i, MigRob and TPS power sources. Digital I/O or AD Combi I/O is needed for WeldGuide functions. Requires option WeldGuide MultiPass [815-2].

Installation kit

Option	Type	Description
715-1	Installation kit	See <i>Product specification - Controller IRC5 with FlexPendant</i> , list of variants

2.6 Process equipment

Torch service

Option	Type	Description
1037-1	ABB TSC	ABB Torch Service Center
1037-2	ABB TC96	ABB Torch Cleaner
1037-5	BullsEye	BullsEye stand alone

Torch service options

Option	Type	Description
1038-1	Extension pedestal	Extension pedestal for TSC/TC/BullsEye

2 Specification of variants and options

2.7 User documentation

2.7 User documentation

User documentation

The user documentation describes the robot in detail, including service and safety instructions.

All documents can be found via myABB Business Portal, www.myportal.abb.com.

3 Robot description

3.1 Robot types

Robot types

There are different variants of the IRB 2600, Type A and Type B, and they may have different motor types; i.e the silver label says it is a Type A robot, but it may use Type B motors. The following table explains the differences.

	IRB 2600 (standard variants)	IRB 2600ID
Initial version	motor type A	motor type A
IRB 2600 Type A	Axis 2 changes gearbox	Axis 1-5 change to motor type B Axis 6 keeps motor type A
IRB 2600 Type B	Axis 1-6 change to motor type B	

This page is intentionally left blank

4 Accessories

4.1 Introduction to accessories

General

There is a range of tools and equipment available, especially designed for the manipulator.

Basic software and software options for robot and PC

For more information, see *Product specification - Controller IRC5 with FlexPendant* and *Product specification - Controller software IRC5*.

Robot peripherals

- Track Motion
- Motor Units
- Positioners

This page is intentionally left blank

Index

A

Absolute Accuracy, 32
 MultiMove, 33
Absolute Accuracy, calibration, 30
accessories, 83

C

calibration
 Absolute Accuracy type, 29
 standard type, 28
calibration, Absolute Accuracy, 30
Calibration Pendulum, 31
CalibWare, 29
category 0 stop, 65
category 1 stop, 65
compensation parameters, 32

D

documentation, 80

E

Electronic Position Switches, 73
EPS, 73

F

fine calibration, 31

I

instructions, 80

M

manuals, 80

O

options, 69

P

product standards, 20

S

safety standards, 20
service instructions, 80
standards, 20
 ANSI, 21
 CAN, 21
 EN, 20
 EN IEC, 20
 EN ISO, 20
standard warranty, 74
stock warranty, 74
stopping distances, 65
stopping times, 65

U

user documentation, 80

V

variants, 69

W

warranty, 74



ABB AB, Robotics

Robotics and Motion

S-721 68 VÄSTERÅS, Sweden

Telephone +46 (0) 21 344 400

ABB AS, Robotics

Robotics and Motion

Nordlysvegen 7, N-4340 BRYNE, Norway

Box 265, N-4349 BRYNE, Norway

Telephone: +47 22 87 2000

ABB Engineering (Shanghai) Ltd.

Robotics and Motion

No. 4528 Kangxin Highway

PuDong District

SHANGHAI 201319, China

Telephone: +86 21 6105 6666

ABB Inc.

Robotics and Motion

1250 Brown Road

Auburn Hills, MI 48326

USA

Telephone: +1 248 391 9000

abb.com/robotics