

IRB 2600

ABB further extends its mid range robot family



The IRB 2600 is the second model in the sharp generation range with enhanced and new capabilities. It is a compact robot with a high payload capacity. The design has been optimized for targeted applications like arc welding, material handling and machine tending. The IRB 2600 is available in three variants, with options for floor, wall, shelf, tilted or inverted mounting configurations.

Sharp accuracy

With the best accuracy in its class, the IRB 2600 can help you increase output with higher process speeds and lower scrap rates, resulting in improved productivity. This is particularly useful in process applications, such as arc welding. The high accuracy is achieved by use of the patented TrueMove™ motion control software.

Short cycle times

Thanks to the compact and optimized design resulting in a low weight, the IRB 2600 can cut the cycle times of the industry benchmark by up to 25 %. The patented QuickMove™ motion control software ensures that the maximum acceleration achievable is highest in its class, together with high maximum speeds. The benefit is increased production capacity and high productivity.

Large working range

The combination of large working range and flexible mounting makes it possible to reach machines to be served without interfering with auxiliary equipment. By optimising the robot placement, you'll benefit from higher productivity. Flexible mounting is also very useful when you are simulating the best position for your application.

Compact design

The IRB 2600 has the same small foot print as IRB 4600. With the IRB 2600 you can create your production cell with reduced floorspace by placing the robot closer to the served machines. The robots' design makes it easier for the lower arm to reach straight downwards.

Best protection available

ABB has the most comprehensive protection program for industrial robots on the market. The IRB 2600 has IP67 as standard and FoundryPlus 2 as option.

Main applications

- Arc Welding
- Assembly
- Material Handling
- Machine Tending
- Material Removal
- Cleaning/Spraying
- Dispensing
- Packing

Specification

Robot version	Reach (m)	Handling capacity (kg)	Wrist torque (Nm)	
			Axis 4 & 5	Axis 6
IRB 2600-20/1.65	1.65	20	36.3	16.7
IRB 2600-12/1.65	1.65	12	21.8	10
IRB 2600-12/1.85	1.85	12	21.8	10
Number of axes	6+3 external (up to 36 with MultiMove)			
Protection	Standard IP67; optional FoundryPlus 2			
Mounting	Floor, wall, shelf, tilted, inverted			
Controller	IRC5 Single Cabinet			

Performance (according to ISO 9283)

	Position repeatability	Path repeatability
IRB 2600-20/1.65	0.04 mm	0.13 mm
IRB 2600-12/1.65	0.04 mm	0.14 mm
IRB 2600-12/1.85	0.04 mm	0.16 mm

Technical information

Electrical Connections

Supply voltage	200-600 V, 50/60 Hz
Energy consumption	3.4 kW

Physical

Robot base	676 x 511 mm
Robot height	
IRB 2600-20/1.65	1382 mm
IRB 2600-12/1.65	1382 mm
IRB 2600-12/1.85	1582 mm
Robot weight	
IRB 2600-20/1.65	272 kg
IRB 2600-12/1.65	272 kg
IRB 2600-12/1.85	284 kg

Environment

Ambient temperature for mechanical unit	
During operation	+5°C (41°F) up to +50°C (122°F)
During transportation and storage	-25°C (13°F) up to +55°C (131°F)
During short periods (max. 24 h)	up to +70°C (158°F)
Relative humidity	Max. 95%
Noise level	Max. 69 dB (A)
Safety	Double circuits with supervision, emergency stops and safety functions, 3-positions enable device.
Emission	EMC/EMI-shielded
Options	Foundry Plus 2

Data and dimensions may be changed without notice.

Movement

Axis movement	Working range	Axis max speed
Axis 1 rotation	+180° to -180°	175°/s
Axis 2 arm	+155° to -95°	175°/s
Axis 3 arm	+75° to -180°	175°/s
Axis 4 rotation	+400° to -400° Max. rev: +251 to -251	360°/s
Axis 5 band	+120° to -120°	360°/s
Axis 6 turn	+400° to -400° Max. rev: + 274 to - 274	500°/s

A supervision function prevents overheating in applications with intensive and frequent movements.

Working range, IRB 2600-20/1.65, IRB 2600-12/1.65

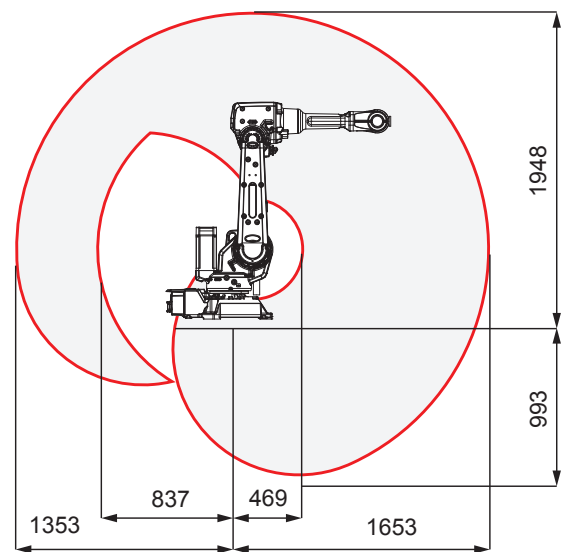

Working range, IRB 2600-12/1.85

