



Low voltage AC drives

ABB drives for water and wastewater

ACQ580

0.75 to 250 kW

Catalog

ACQ580 series

Specialized for the most commonly required pump functions, this drive series brings together built-in pump application functionalities and single and multi-pump system configurations. This capability ensures accurate waterflow control in all applications including raw water, utilization and wastewater treatment.

Contents

4	The energy efficient drive for water and wastewater pumping
6	All-compatible solutions for water and wastewater applications
8	Secure energy efficient flow of water and wastewater in your pumping solutions
10	Securing the flow of water and wastewater in the pump system
12	How to select a drive
13	Technical specification
14	Securing the flow of water and wastewater with ACQ580-01
15	ACQ580-01 ratings, types and voltages
16	Pump control program
17	Comprehensive connectivity
18	Built-in pump application software
20	Ultimate efficiency and reliability to optimize your pump system cost of ownership
21	Selection guide - IE4 synchronous reluctance motors
22	Effortless drive commissioning and use with control panels
23	Save time, ease troubleshooting and improve drive performance with ABB smartphone apps
24	Quick configuration for unpowered drives, PC tools for drive monitoring and process tuning capabilities, Remote monitoring access worldwide
25	Flexible connectivity to automation networks, Input/output extension modules for increased connectivity
26	EMC - electromagnetic compatibility
27	Du/dt filters
28	Cooling and fuses
29	ABB automation products
30	Drives service - Your choice, your future
31	Drives service - A lifetime of peak performance

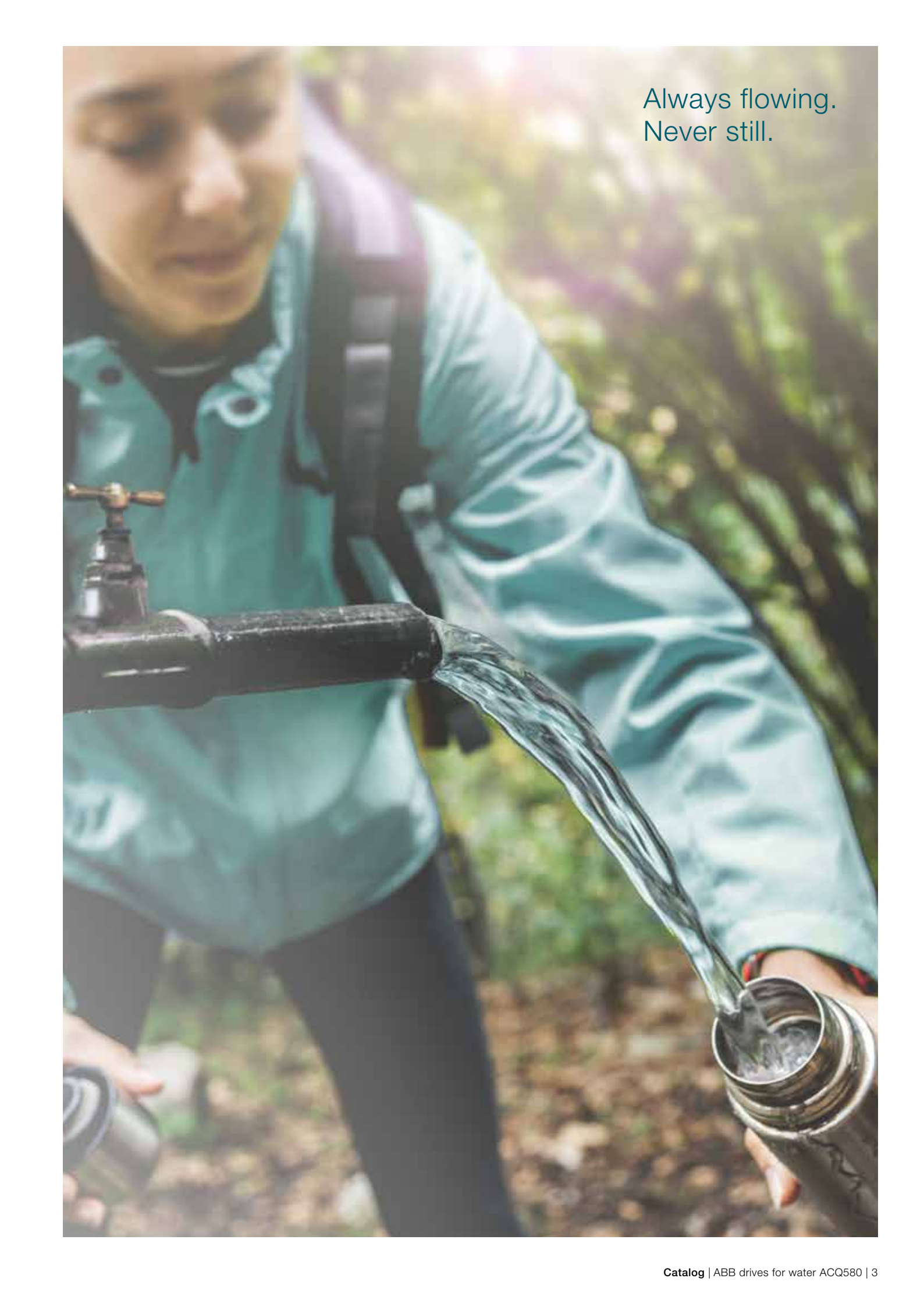
A woman wearing a teal jacket and a backpack is filling a silver water bottle from a public tap in a park. The water is flowing from the tap into the bottle. The background is a blurred green forest with sunlight filtering through the trees.

Always flowing.
Never still.

The energy efficient drive for water and wastewater pumping

Whether your pump system requires redundancy in multi-pump applications or built-in pump application functionalities designed for the water and wastewater industry, the ACQ580 is designed to meet your requirements.



Simplicity at your fingertips

The control panel's straightforward primary settings menu with assistants help you set up the drive quickly and effectively.

Speaks water specific terminology

The drive has built-in pump application control programs to secure optimal operation of the water and wastewater pump.

Boosting energy efficiency

The energy optimizer helps you to save energy, and the energy efficiency information made available to you help monitor and save the energy used in your processes.



Remote monitoring solutions

Remote monitoring via standard web browsers will help reduce costs by reducing the amount of routine site visits.

Controls virtually any kind of motor

The drive has the ability to control almost any motors from induction and permanent magnet motors to synchronous reluctance motors.



The ACQ580 water and wastewater drives are part of ABB's all-compatible drives portfolio. The drives secure the flow of water and wastewater in the pumping system throughout their whole life cycle. The ACQ580 drive is easy to commission and use. With built-in pump functionalities, the drive keeps the pumping system operating optimally, lowering the energy bill. The drive is used in water and wastewater treatment plants, pumping stations, desalination plants, industrial wastewater facilities and irrigation environments. The drive is used with inflow pumps, transfer pumps, dosing pumps, sludge pumps, booster pumps, submersible pumps and compressors, blowers, decanter centrifuges, mixers and fans.



Startup and maintenance tool

Drive composer PC tool for startup, configuration, monitoring and process tuning. The PC tool is connected to the drive's control panel via USB.



Robust with built-in features

A robust performer that is simple to select, and easy to install and use. Built-in features such as an EMC filter, choke, a Modbus RTU fieldbus interface and safe torque off (STO) functionality simplify drive selection, installation and use.

Reliable communication

With its wide range of optional fieldbus adapters, the drive enables connectivity with all major automation networks and control systems.



Input/output extensions

In addition to the standard interfaces, the drive has a built-in slot for additional input/output extension modules.



All-compatible solutions for water and wastewater applications

Environment all-compatible

Achieve your environmental goals with our energy-efficient drive for water and wastewater. The all-compatible drives offer built-in energy efficiency calculators. They help you to analyze and optimize your pump processes to reduce stress on the environment. Other environmentally friendly features include the built-in soft pipe fill function to ensure less water hammering on the water pipes, thus preventing the risk of unwanted leaks, unplanned outage and repair costs.

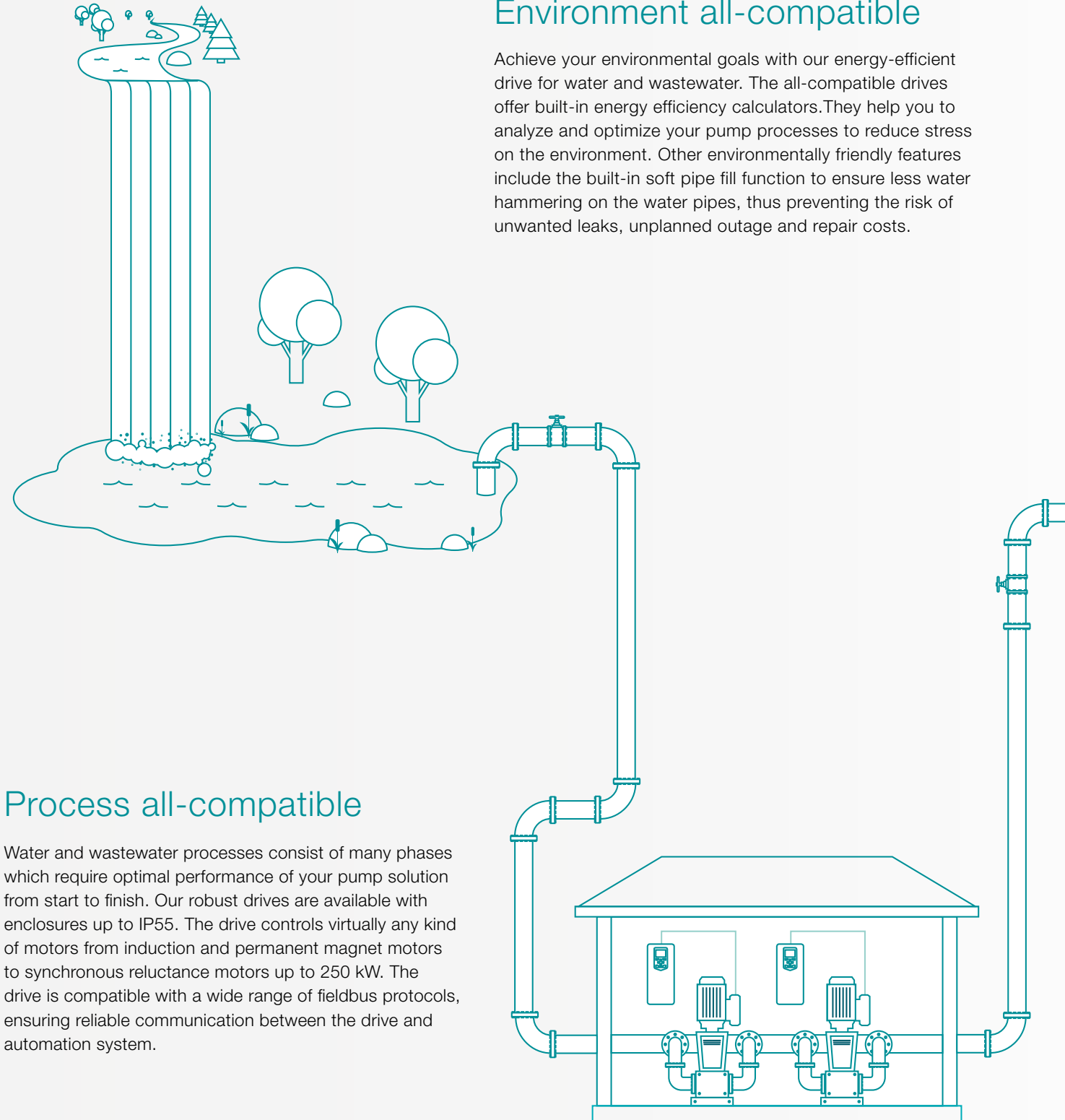

Process all-compatible

Water and wastewater processes consist of many phases which require optimal performance of your pump solution from start to finish. Our robust drives are available with enclosures up to IP55. The drive controls virtually any kind of motors from induction and permanent magnet motors to synchronous reluctance motors up to 250 kW. The drive is compatible with a wide range of fieldbus protocols, ensuring reliable communication between the drive and automation system.

Business all-compatible

As a reliable global partner, we provide water process solutions that keep the life cycle costs of your pump solution stable. Additionally, we help keep your water process productive and consistent in an energy efficient way. Our wide range of water industry products and solutions offer optimal flow of water all hours of the day. This means lower energy consumption, improved productivity, flexibility and ease of use. With offices in over 90 countries and a global technical partner network, we offer technical advice and local support worldwide.

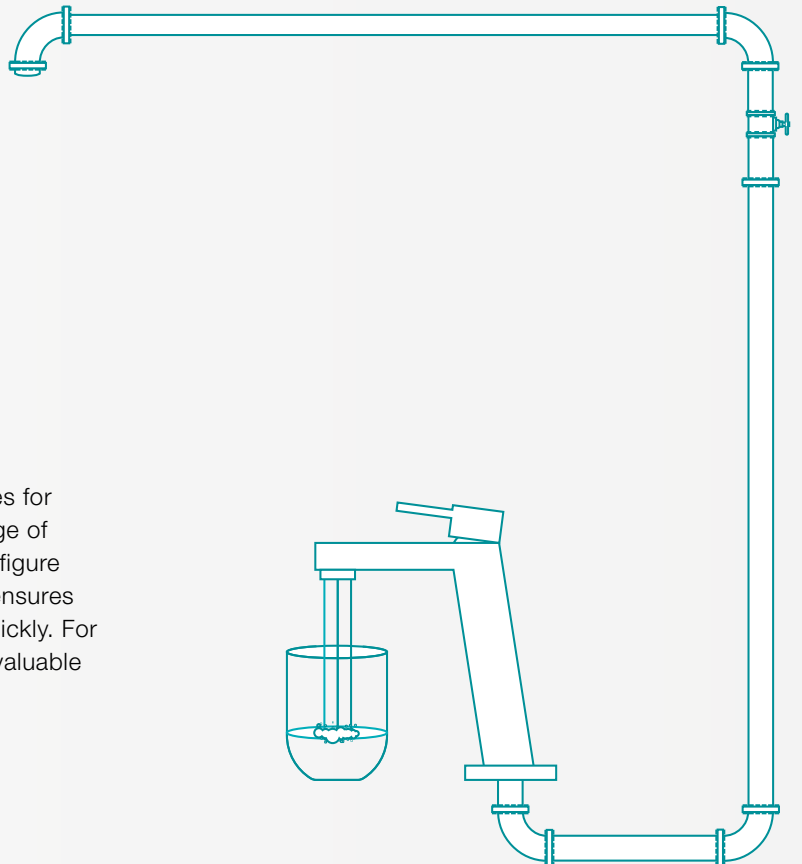
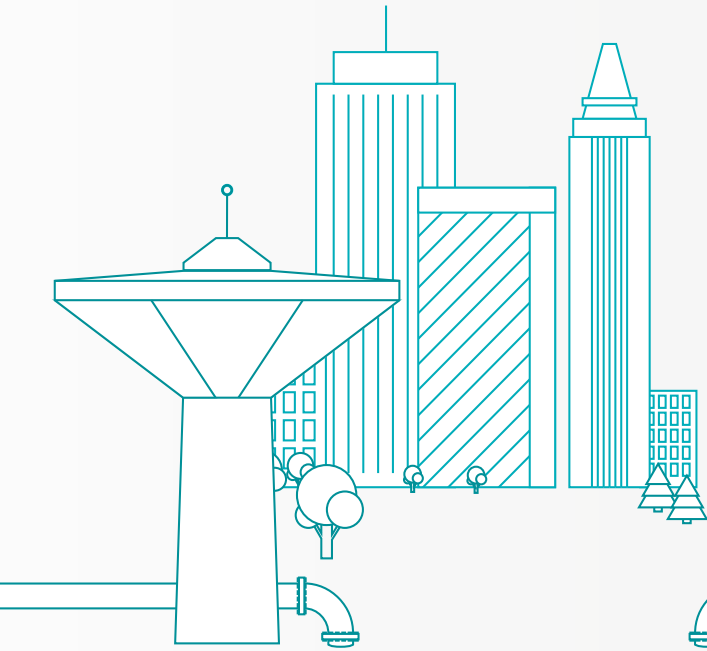

Human all-compatible

You can feel confident using our all-compatible drives for water and wastewater. The drive speaks the language of your pump application making it easy to set up, configure and use. The intuitive Hand-Off-Auto control panel ensures that you have access to the essential information quickly. For accessing your drive from a distance and receiving valuable analytics we offer remote monitoring solutions.

Secure energy efficient flow of water and wastewater in your pumping solutions

The ACQ580 water and wastewater drive is built to help users, designers, OEMs, system integrators and EPC professionals secure pumping of water and wastewater in municipal utilities, pumping stations, industrial wastewater facilities, desalination plants and irrigation environments. It offers long-term, technically-compatible drive solutions supported by full service and support. For availability of the built-in pump application software please check with your local ABB.

Soft pipe filling

Increase the lifetime of the piping and pump system by avoiding pressure peaks.

Quick ramps

Extend the lifecycle of a submersible pump by reducing wear of the mechanical parts using ramp sets to accelerate and decelerate the pump.

Pump priority

Achieve energy savings with optimal pump alternation by running the higher capacity pump when the consumption rate is higher.

Anti-cavitation

Extend the pump lifetime and secure the process by detecting cavitation and ensuring the optimal speed.





Auto-change

Increase the mean time between repairs and save in service costs by balancing the long-term operating time of all pumps in a parallel pumping system.

Sleep boost

Save energy while extending the life of the pump and motor by decreasing start/stop cycles during all hours of the day.

Sensorless flow calculation

Reduce costs by eliminating external components or backup the flow meters to avoid interruptions in the process.

Pump cleaning

Achieve savings by preventing unplanned downtime as a result of accumulating obstructions being removed from the impeller of the pump.

Multi-pump control

Ensure stable and uninterrupted production with multi-pump controls by optimizing the speed and number of running pumps.

Securing the flow of water and wastewater in the pump system

We want to be part of securing the operation of your water and wastewater utilities and distribution system. We want to help prevent any interruptions in your pump operation. We also want to assure that the water is flowing in an effortless and energy efficient manner in accordance with required standards and regulations.

Complete offering of devices and service for the water industry

As a global partner, we can manage your water assets and bring you clear benefits from a total cost of ownership perspective. We do this by reducing costs throughout the whole life cycle of your pumping solution. Our portfolio includes drives, motors, PLC's and sensors. We also offer remote monitoring solutions to access information from a pump operating at a distance, saving time and reducing costs. Our devices have been designed to be compatible with each other, which ensures reliable communication and functionality.

Proactive maintenance for minimizing disruption to your pump and water distribution system

Motor-driven applications can be found throughout the water and wastewater industry. They have a high degree of reliance placed upon them and often perform critical duties and have a high in-service value. A possible failure of a device in the water and wastewater distribution system can result in loss of production, and introduce safety and environmental consequences. To reduce the risk of failure, each element of the pump solution - whether a drive, motor, bearing, coupling or gearing - must be properly maintained at the right times in their life cycle. From the moment you make the first enquiry to the disposal and recycling of each component, the services offered by ABB span the entire life cycle of your pump. Throughout the value chain, training, technical support and customized contracts are also available.





How to select a drive

It is very easy to select the right drive.

This is how you build up your own ordering code using the type designation key.

1 Start with identifying your supply voltage.
This tells you what rating table to use.
The ACQ580 supports 380 to 480 V.

2 Choose your motor's nominal power rating from the ratings table on page 15.

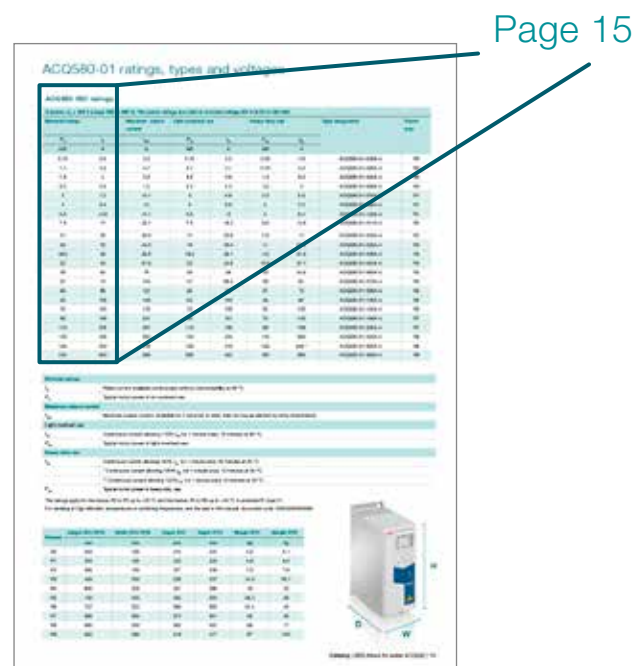

4 Choose your options. Details about each option begin on page 15. Add the option codes to the end of the drive's ordering code. Remember to use a "+" before each option code.

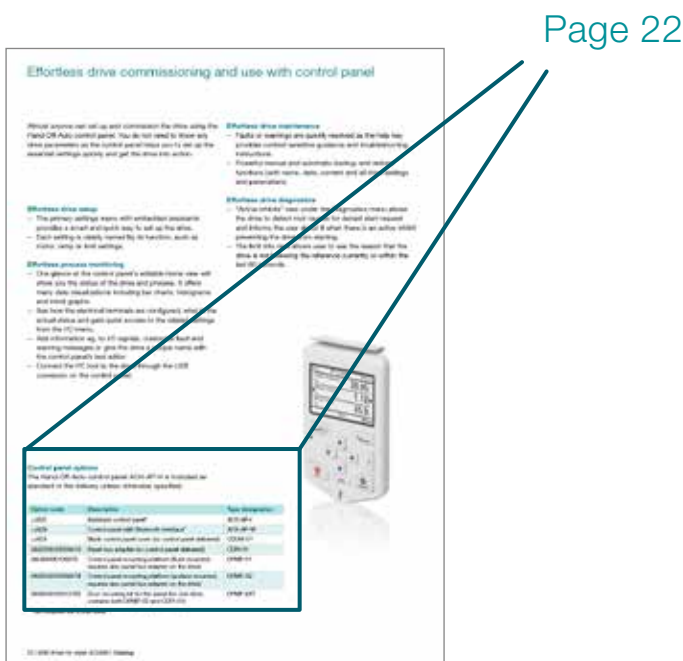

3 Select your drive's type code from the rating table based on your motor's nominal power rating.

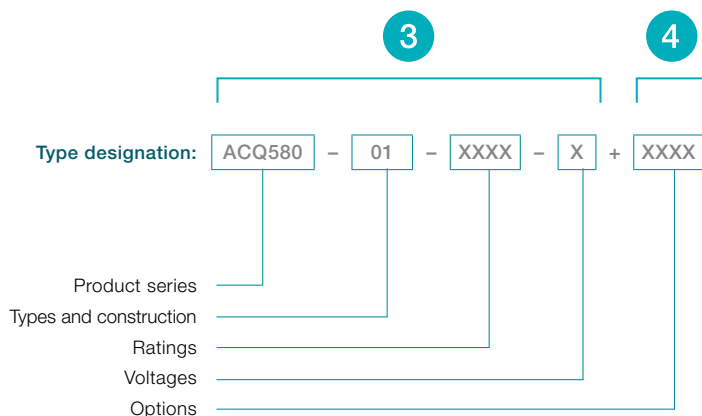
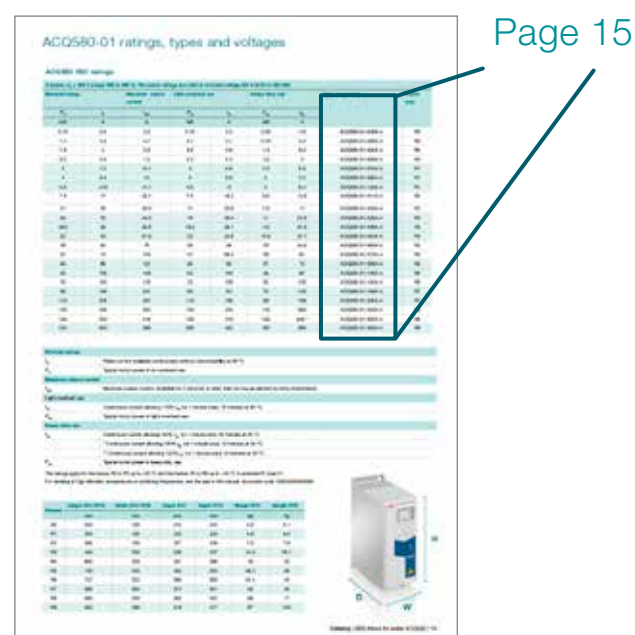

Technical specification



Mains connection

Voltage and power range	3-phase, U_N 380 to 480 V, +10%/-15% From 0.75 up to 250 kW
Frequency	50/60 Hz $\pm 5\%$
Power factor	$\cos\varphi = 0.98$
Efficiency (at nominal power)	98%

Motor connection

Voltage	0 to U_N , 3-phase
Frequency	0 to 500 Hz
Motor control	Scalar and vector control
Torque control	Torque step rise time: <10 ms with nominal torque Non-linearity: $\pm 5\%$ with nominal torque
Speed control	Static accuracy: 20% of motor nominal slip Dynamic accuracy: 1% seconds with 100% torque step

Product compliance

CE
 Low Voltage Directive 2006/95/EC, EN 61800-5-1: 2007
 Machinery Directive 2006/42/EC, EN 61800-5-2: 2007
 EMC Directive 2004/108/EC, EN 61800-3: 2004 + A1: 2012
 RoHS directive 2011/65/EU
 Quality assurance system ISO 9001 and Environmental system
 RCM
 ISO 14001
 EAC
 UL

EMC according to EN 61800-3: 2004 + A1: 2012

ACQ580-01 wall-mounted drive with built-in C2 category filter as standard (frames R0 to R9)

Environmental limits

Ambient temperature	
Transport	-40 to +70 °C
Storage	-40 to +70 °C
Operation area	Frames R0 to R3: -15 to +50 °C. No derating required, no frost allowed. Frames R4 to R9: -15 to +40 °C. No derating required, no frost allowed, +40 to +50 °C derating required, see HW manual for more information.
Cooling method	
Air-cooled	Dry clean air
Altitude	
0 to 1,000 m	Without derating
1,000 to 4,000 m	With derating of 1%/100 m
Relative humidity	5 to 95%, no condensation allowed
Degree of protection	IP21 as standard, IP55 as an optional variant (frames R0 to R9)
Functional safety	Safe torque off (STO according EN 61800-5-2) IEC 61508 ed2: SIL 3, IEC 61511: SIL 3, IEC 62061: SIL CL 3, EN ISO 13849-1: PL e
Contamination levels	No conductive dust allowed
Storage	IEC 60721-3-1, Class 1C2 (chemical gases), Class 1S2 (solid particles)*
Operation	IEC 60721-3-3, Class 3C2 (chemical gases), Class 3S2 (solid particles)*
Transportation	IEC 60721-3-2, Class 2C2 (chemical gases), Class 2S2 (solid particles)*

* C = chemically active substances

S = mechanically active substances

Securing the flow of water and wastewater with ACQ580-01

The wall-mounted ACQ580-01 is a robust and compact drive ensuring low energy consumption and continuous, reliable motor control with a power and voltage range from 0.75 to 250 kW and 380 to 480 V. It has coated boards and offers enclosure classes IP21 and IP55 for different environments. The drive is designed for water and wastewater pumps, blowers, mixers, centrifuges and fans.

Built-in pump functionality for optimal flow of water

Built-on ABB's common drives architecture, the wall-mounted drive offers pump operation, energy saving and usability benefits supported by a local network of service and support. The water and wastewater drive offers several different built-in pump application programs for optimal pump operation. For more information, see page 18. The ACQ580-01 is easy to mount on walls and can be situated in dusty and wet environments.

Intuitive usability supported by simple connectivity

To ensure fast set-up and operation of the wall-mounted drive, adjusting drive settings has been made easy with the robust and intuitive Hand-Off-Auto control panel. The control panel has a powerful diagnostics menu that makes it possible to quickly access information, even in facilities with poor visibility. Drive usability is further enhanced via wireless Bluetooth connectivity between the drive and mobile devices, making it easy to access the drive in difficult-to-reach locations. Connectivity to automation systems is ensured with the drive connecting to various fieldbus protocols. To ensure compliance with electric grids, the ACQ580-01 has a built-in 1st environment EMC filter and choke. The drive also supports functional safety design, as it offers integrated safety features with safe torque off (STO) built-in as standard. The wall-mounted drive offers flange mounting as an option, separating the control electronics from the main circuit cooling airflow, saving space and ensuring optimal cooling. This results in better thermal management during panel installation.



Robust and compact with enclosure IP55



Flange mounting for panel installation ensures less thermal load inside panel by keeping most of the losses outside the panel.

ACQ580-01 ratings, types and voltages

ACQ580-01 IEC ratings

3-phase, $U_N = 400$ V (range 380 to 480 V). The power ratings are valid at nominal voltage 400 V (0.75 to 250 kW)

Nominal ratings		Maximum output current	Light-overload use		Heavy-duty use		Type designation	Frame size
P_N	I_N	I_{max}	P_{Ld}	I_{Ld}	P_{Hd}	I_{Hd}		
kW	A	A	kW	A	kW	A		
0.75	2.6	3.2	0.75	2.5	0.55	1.8	ACQ580-01-02A6-4	R0
1.1	3.3	4.7	1.1	3.1	0.75	2.6	ACQ580-01-03A3-4	R0
1.5	4	5.9	1.5	3.8	1.1	3.3	ACQ580-01-04A0-4	R0
2.2	5.6	7.2	2.2	5.3	1.5	4	ACQ580-01-05A6-4	R0
3	7.2	10.1	3	6.8	2.2	5.6	ACQ580-01-07A2-4	R1
4	9.4	13	4	8.9	3	7.2	ACQ580-01-09A4-4	R1
5.5	12.6	14.1	5.5	12	4	9.4	ACQ580-01-12A6-4	R1
7.5	17	22.7	7.5	16.2	5.5	12.6	ACQ580-01-017A-4	R2
11	25	30.6	11	23.8	7.5	17	ACQ580-01-025A-4	R2
15	32	44.3	15	30.4	11	24.6	ACQ580-01-032A-4	R3
18.5	38	56.9	18.5	36.1	1.5	31.6	ACQ580-01-038A-4	R3
22	45	67.9	22	42.8	18.5	37.7	ACQ580-01-045A-4	R3
30	62	76	30	58	22	44.6	ACQ580-01-062A-4	R4
37	73	104	37	68.4	30	61	ACQ580-01-073A-4	R4
45	88	122	45	83	37	72	ACQ580-01-088A-4	R5
55	106	148	55	100	45	87	ACQ580-01-106A-4	R5
75	145	178	75	138	55	105	ACQ580-01-145A-4	R6
90	169	247	90	161	75	145	ACQ580-01-169A-4	R7
110	206	287	110	196	90	169	ACQ580-01-206A-4	R7
132	246	350	132	234	110	206	ACQ580-01-246A-4	R8
160	293	418	160	278	132	246 *	ACQ580-01-293A-4	R8
200	363	498	200	345	160	293	ACQ580-01-363A-4	R9
250	430	545	200	400	200	363 **	ACQ580-01-430A-4	R9

Nominal ratings

I_N	Rated current available continuously without overloadability at 40 °C.
P_N	Typical motor power in no-overload use.

Maximum output current

I_{max}	Maximum output current. Available for 2 seconds at start, then as long as allowed by drive temperature.
-----------	---

Light-overload use

I_{Ld}	Continuous current allowing 110% I_{Ld} for 1 minute every 10 minutes at 40 °C.
P_{Ld}	Typical motor power in light-overload use.

Heavy-duty use

I_{Hd}	Continuous current allowing 150% I_{Ld} for 1 minute every 10 minutes at 40 °C. * Continuous current allowing 130% I_{Ld} for 1 minute every 10 minutes at 40 °C. ** Continuous current allowing 125% I_{Ld} for 1 minute every 10 minutes at 40 °C.
P_{Hd}	Typical motor power in heavy-duty use.

The ratings apply for the frames R0 to R3 up to +50 °C and the frames R4 to R9 up to +40 °C in enclosed IP class 21
For derating at high altitudes, temperatures or switching frequencies, see the user's HW manual, document code: 3AXD50000035866

Frames	Height IP21/IP55	Width IP21/IP55	Depth IP21	Depth IP55	Weight IP21	Weight IP55
	mm	mm	mm	mm	kg	kg
R0	303	125	210	222	4.5	5.1
R1	303	125	223	223	4.6	5.5
R2	394	125	227	239	7.5	7.8
R3	454	203	228	237	14.9	15.1
R4	600	203	257	265	19	20
R5	732	203	295	320	28.3	29
R6	727	252	369	380	42.4	43
R7	880	284	370	381	54	56
R8	965	300	393	452	69	77
R9	955	380	418	477	97	103



Pump control program



The pump control program of the ACQ580 contains built-in preprogrammed features that save time during drive commissioning, configuration and operation of water and wastewater pumpings solutions.

Commissioning made easier than ever before

The drives' Hand-Off-Auto control panel has a clear and intuitive user interface as well as different assistants to make the drive simple to set up and use. This saves on commissioning and learning time.

Startup assistant

The intelligent and intuitive startup assistant allows first time users to quickly customize the drive, out of the box, according to their needs. This is complemented by a built-in help function to make parameter-by-parameter setting easy. These features allow the drive to be quickly commissioned, even without manuals.

Optimize energy use

The drives come with features that help you save and manage energy. The energy optimizer feature operates both in scalar and vector control modes, ensuring maximum torque per ampere and reducing energy drawn from the supply. You can monitor the hourly, daily and cumulative energy consumption via kWh counters. When the drive replaces other control methods (eg, direct-online control), you can follow the saved energy, CO₂ emissions or money, and see how fast the drive brings you a return on investment.

Sophisticated process control

The drives offer sophisticated process control in scalar and vector control modes. The drive supports a wide range of motors including induction, permanent magnet and synchronous reluctance motors. Many embedded protection and other features improve performance of the motor and process.

Reduce motor noise

The drive reduces motor noise by spreading the switching frequencies over a user-specified range. Users can define an allowed range of used switching frequency. As a result,

the drive maximizes the actual used switching frequency based on thermal measurement. The higher used switching frequency reduces motor noise at low load without limiting full current at maximum load.

Pump control

The pump control functionality includes auto-change and control of auxiliary pumps with contactor/soft starter control via relay outputs. In a pressure control pump system the pump control functionality of the drive is useful when various pumps are operated in parallel mode at the same time and the flow required is variable. The functionality provides balanced and optimal operation at different loading points due to equal duty times between auxiliary motors. The pump control connects motors on-line from zero speed. One drive controls several pumps or blowers in parallel and eliminates the need for an external programmable logic controller. This results in reduced stress on the mains and the system as well as in lower maintenance and operation costs.

Diagnostic menu

The drive is equipped with a diagnostic assistant that helps in locating the cause of any disturbance to the drive, and even suggests possible remedies. This reduces process downtime by making repairs or adjustments effortless.

PID built-in

Built-in and stand-alone process PID / loop controller makes the drive a self-governing unit that requires no external logic input from the control room, but requires only an external process measurement. The sleep mode with boost functionality elevates the required level of operation momentarily eg, level or pressure of fluid, just before turning to sleep mode. This prolongs the time spent in sleep mode and saves energy.

Load profile

Drive values, such as current, are collected by the load profile feature and stored in a log. The log shows how the drive is operating and enables you to analyze and optimize the application, to analyze historical load and optimize the application.

Comprehensive connectivity

The ACQ580 drives offer a wide range of standard interfaces. In addition, the drive has two option slots that can be used for extensions including fieldbus adapter modules and input/output extension modules.

Default control connections to the CCU-23 control unit

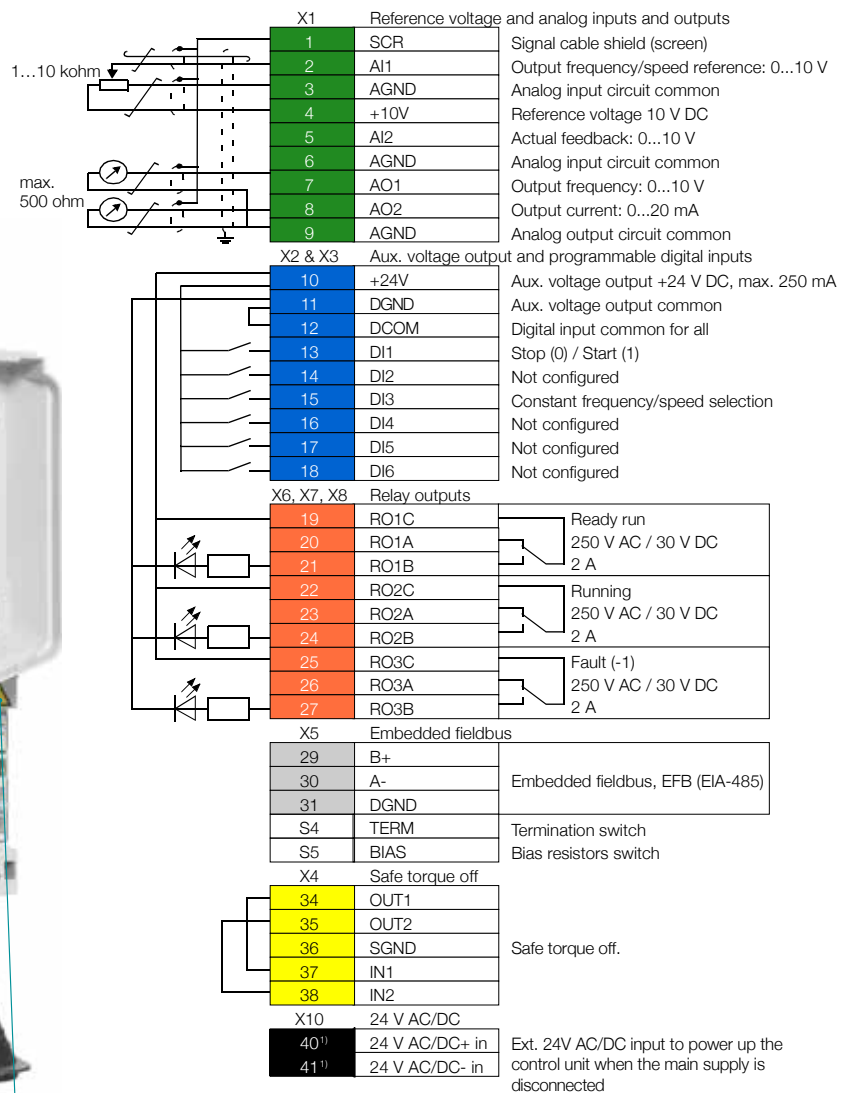
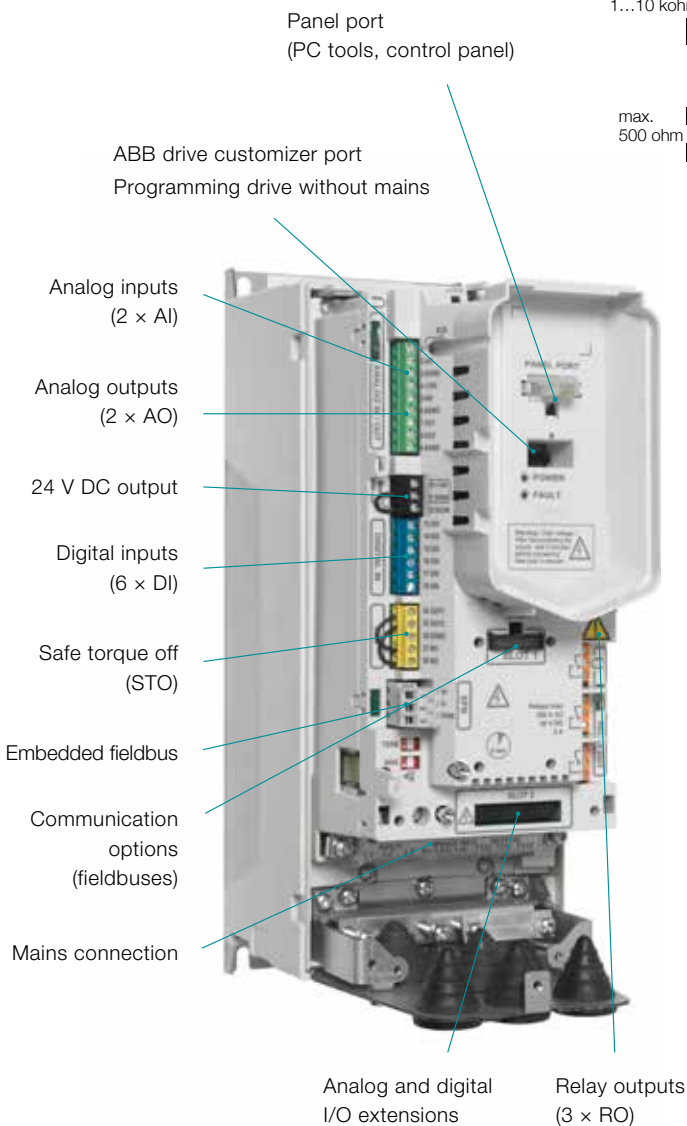

1) Only available in CCU-24 control unit

Built-in pump application software

The built-in pump application software in the ACQ580 drives is designed to enhance the reliability and durability of the water and wastewater application in which it is used. The functions* protect the pump and secure its optimal functionality, increasing cost efficiency. The built-in functionalities also support the user in securing the flow of the water and wastewater in the pump solution.

Multi-pump functionality

This built-in functionality ensures operation in parallel, for multi-pump systems if one or more pumps fails or requires maintenance. The functions maintains stable process conditions for several parallel pumps (up to 8 pumps at the same time) operating together. Optimize the speed and number of pumps needed when the required flow rate is variable.

Sensorless flow calculation

Ensure the appropriate amount of water flowing without the need for external sensors. Reduce costs as there is no need for setting up and using additional sensors.

Level control

Control the filling or emptying of wastewater storage and water tower tanks. Level control can be used within a station controlling up to eight pumps. The level control function allows the tank to be filled to a maximum level, then pump the tank to a pre-set low level. This method allows the pumps to run at a efficient speed and ensures the pump sump does not become over contaminated by sediment.

Soft pipe fill

The soft pipe fill function manages the pressure of water filling the pipeline with a gentle approach. This reduces the risk of water hammer which can cause damage to the water pipes.

End of pump curve

Here the drive is operating at a set speed and detection is based on the measurement of the pressure and the speed of the motor. A sudden drop in pressure and an acceleration to maximum speed reference is referring to a pipe burst or leakage in the system.

Quick-ramp

Protect bearings when a submersible pump is started without water. Quick ramp allows your pump to reach optimal speed to ensure operation, extend pump life and prevent unplanned outages.

Pump cleaning

Keeps the impeller of the pump clean running a sequence of aggressive ramps between minimum and maximum pump speed.

Dry pump protection

Prevent your pump from running dry. Protect bearings and shaft seal from damage when there is no water in the pump.

Anti-cavitation

Cavitation can happen in flow systems when the pressure in water suddenly drops. It causes vapour bubbles and when the bubbles collapse, they can be destructive to pumps internal components.

Tank flush / Sump cleaning

Fully empty your tank and prevent sludge build up at the bottom of the tank.

Pipe cleaning

When pipe cleaning is needed, pumps will run at maximum speed to flush the pipe system. The outlet limits for flow rate of pressure will restrict the maximum speed actually used in this function.

Turbidity reduction

When a pump starts as slow as possible, it creates the lowest turbidity values for the water being moved or extracted. When you combine the quick ramps and soft pipe fill functions, the drive will adjust the second acceleration rate to the best value possible based on your application needs.

* For availability please contact your local ABB



Ultimate efficiency and reliability to optimize your pump system cost of ownership



Traditional IE2 induction motor



IE4 SynRM motor

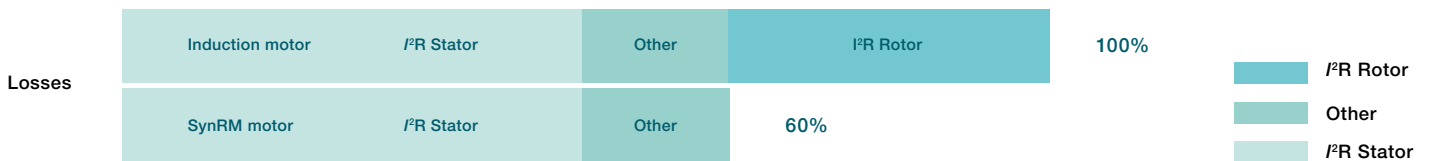

Innovation inside

The idea is simple. Take a conventional, proven stator technology and a totally new, innovative rotor design. Then combine them with a dedicated water industry drive loaded with new, application-designed software. Finally, optimize the whole package for pumping applications.

Magnet-free design

Synchronous reluctance technology combines the performance of the permanent magnet motor with the simplicity and service-friendliness of an induction motor. The new rotor has neither magnets nor windings and suffers virtually no power losses. And because of identical footprints, maintenance is as straightforward as with induction motors.

Superior reliability to minimize the cost of not running

IE4 synchronous reluctance motors have very low winding temperatures, which increases the reliability and lifetime of the winding. More importantly, the cool synchronous reluctance rotor means significantly lower bearing temperatures – an important factor because bearing failures cause about 70 percent of unplanned motor outages.



Selection guide

IE4 synchronous reluctance motors

This table presents technical performance data for IE4 SynRM motors. Variant codes and construction details are based on the M3BP motor. Protection IP55, cooling IC 411, insulation class F, temperature rise class B. Motor values are given with an ACQ580 drive supply.

Output kW	Motor type			Product code	Speed n_n r/min	Frequency f_{el} Hz	Motor efficiency with drive supply %	Current I_N A	Torque T_N Nm	Package efficiency ** IES at nominal point (PN)	PDS*** IES2 efficiency class low limit	Above IES2 low limit in % -units	Above IES2 low limit in % -units	Motor weight m kg	Suggested ACQ580 drive for no overload pump use*	Frame size
3000 rpm					400 V network											
1.5	M3AL	90	L 4	3GAL 092 507-_SB2)	3000	100	84.2	3.9	4.8	82.1	76.2	5.9	7.7	13	ACQ580-01-04A0-4	R0
2.2	M3AL	90	LA 4	3GAL 092 517-_SB2)	3000	100	85.9	5.6	7.0	83.8	78.3	5.4	6.9	13	ACQ580-01-05A6-4	R0
3	M3AL	100	LB 4	3GAL 102527-_SB1)2)	3000	100	88.6	9.5	9.6	86.4	79.8	6.6	8.2	23	ACQ580-01-12A6-4	R1
4	M3AL	112	MB 4	3GAL 112327-_SB1)2)	3000	100	89.9	13.6	12.7	87.7	81.1	6.5	8.1	33	ACQ580-01-017A-4	R2
5.5	M3AL	132	SMA 4	3GAL 132217-_SC	3000	100	90.9	12.6	17.5	88.4	82.5	6.0	7.2	41	ACQ580-01-12A6-4	R1
7.5	M3AL	132	SMB 4	3GAL 132227-_SC	3000	100	91.7	16.9	23.9	89.3	83.9	5.4	6.4	41	ACQ580-01-017A-4	R2
11	M3AL	132	SMC 4	3GAL 132237-_SC	3000	100	92.6	25	35.0	90.0	85.3	4.7	5.5	47	ACQ580-01-025A-4	R2
15	M3AL	132	SMD 4	3GAL 132247-_SC	3000	100	93.3	33.5	47.7	90.7	86.2	4.5	5.2	47	ACQ580-01-038A-4	R3
11	M3BL	160	MLA 4	3GBL 162417-_SC	3000	100	92.6	25.0	35.0	90.2	85.3	4.9	5.8	133	ACQ580-01-025A-4	R2
15	M3BL	160	MLB 4	3GBL 162427-_SC	3000	100	93.3	34.8	48.0	90.5	86.2	4.3	5.0	133	ACQ580-01-038A-4	R3
18.5	M3BL	160	MLC 4	3GBL 162437-_SC	3000	100	93.7	42.8	59.0	91.4	86.9	4.5	5.2	133	ACQ580-01-045A-4	R3
22	M3BL	180	MLA 4	3GBL 182417-_SC	3000	100	94.0	50.0	70.0	91.6	87.3	4.3	4.9	160	ACQ580-01-062A-4	R4
30	M3BL	200	MLA 4	3GBL 202417-_SC	3000	100	94.5	68.8	95.0	92.2	88.1	4.1	4.6	259	ACQ580-01-073A-4	R4
37	M3BL	200	MLB 4	3GBL 202427-_SC	3000	100	94.8	84.6	118	92.7	88.6	4.1	4.7	259	ACQ580-01-088A-4	R5
45	M3BL	225	SMA 4	3GBL 222217-_SC	3000	100	95.0	103	143	92.2	89.0	3.2	3.6	282	ACQ580-01-106A-4	R5
55	M3BL	225	SMF 4	3GBL 222267-_SC	3000	100	95.3	122	175	92.6	89.4	3.2	3.5	282	ACQ580-01-145A-4	R6
1500 rpm																
1.1	M3AL	90	LA 4	3GAL 092 513-_SB2)	1500	50	81.4	2.9	7.0	79.4	74.0	5.4	7.3	13	ACQ580-01-03A3-4	R0
1.5	M3AL	90	LB 4	3GAL 092 523-_SB2)	1500	50	82.8	3.8	9.6	80.7	76.2	4.5	5.9	16	ACQ580-01-04A0-4	R0
2.2	M3AL	100	LB 4	3GAL 102523-_SB1)2)	1500	50	86.2	5.8	14.0	84.0	78.3	5.7	7.3	23	ACQ580-01-07A2-4	R1
3	M3AL	100	LB 4	3GAL 102523-_SB2)	1500	50	85.5	7.1	19.1	83.4	79.8	3.5	4.4	23	ACQ580-01-07A2-4	R1
4	M3AL	112	MB 4	3GAL 112323-_SB1)2)	1500	50	88.0	10.6	25.5	85.8	81.1	4.7	5.8	33	ACQ580-01-12A6-4	R1
5.5	M3AL	132	SMA 4	3GAL 132213-_SC	1500	50	91.9	12.1	35.0	89.6	82.5	7.1	8.6	63	ACQ580-01-12A6-4	R1
7.5	M3AL	132	SMB 4	3GAL 132223-_SC	1500	50	92.6	16.2	47.7	90.1	83.9	6.2	7.4	63	ACQ580-01-017A-4	R2
11	M3AL	132	SMC 4	3GAL 132233-_SC	1500	50	93.3	24	70	90.6	85.3	5.3	6.2	69	ACQ580-01-025A-4	R2
11	M3BL	160	MLA 4	3GBL 162413-_SC	1500	50	93.3	24.9	70	90.9	85.3	5.6	6.6	160	ACQ580-01-025A-4	R2
15	M3BL	160	MLB 4	3GBL 162423-_SC	1500	50	93.9	33.7	95	91.3	86.2	5.1	5.9	177	ACQ580-01-038A-4	R3
18.5	M3BL	180	MLA 4	3GBL 182413-_SC	1500	50	94.2	42.0	118	92.0	86.9	5.1	5.9	177	ACQ580-01-045A-4	R3
22	M3BL	200	MLF 4	3GBL 202463-_SC	1500	50	94.5	49.1	140	92.2	87.3	4.9	5.6	304	ACQ580-01-062A-4	R4
30	M3BL	200	MLA 4	3GBL 202413-_SC	1500	50	94.9	66.7	191	92.6	88.1	4.5	5.1	304	ACQ580-01-073A-4	R4
37	M3BL	250	SMF 4	3GBL 252263-_SC	1500	50	95.2	82.0	236	93.1	88.6	4.5	5.1	428	ACQ580-01-088A-4	R5
45	M3BL	250	SMG 4	3GBL 252273-_SC	1500	50	95.4	99.5	286	92.8	89.0	3.8	4.3	428	ACQ580-01-106A-4	R5
55	M3BL	250	SMA 4	3GBL 252213-_SC	1500	50	95.7	121	350	93.1	89.4	3.7	4.1	454	ACQ580-01-145A-4	R6
75	M3BL	280	SMA 4	3GBL 282213-_DC	1500	50	96.0	173	478	93.6	90.0	3.6	4.0	639	ACQ580-01-206A-4	R7
90	M3BL	280	SMB 4	3GBL 282223-_DC	1500	50	96.1	202	573	93.7	90.2	3.5	3.9	639	ACQ580-01-206A-4	R7
110	M3BL	280	SMC 4	3GBL 282233-_DC	1500	50	96.3	245	699	93.5	90.5	3.0	3.3	697	ACQ580-01-246A-4	R8
110	M3BL	315	SMA 4	3GBL 312213-_DC	1500	50	96.3	244	702	94.0	90.5	3.5	3.9	873	ACQ580-01-246A-4	R8
132	M3BL	315	SMB 4	3GBL 312223-_DC	1500	50	96.4	290	842	94.0	90.7	3.3	3.6	925	ACQ580-01-293A-4	R8
160	M3BL	315	SMC 4	3GBL 312233-_DC	1500	50	96.6	343	1018	94.2	90.9	3.3	3.6	965	ACQ580-01-363A-4	R8
200	M3BL	315	MLA 4	3GBL 312413-_DC	1500	50	96.7	427	1272	94.5	91.1	3.4	3.7	1116	ACQ580-01-430A-4	R9

1) Motor with restamped output required (option +002).

2) Motor non-conformable with IE4 EE class

* Motor type M3AL = aluminum motor frame

* Motor type M3BL = cast iron motor frame

** Calculated package efficiency values for ACH580-01, measured values TBA

***PDS = Power Drive System

Effortless drive commissioning and use with control panels

Easy and fast set up and commissioning of the drive means you can be more efficient with your time. Using the Hand-Off-Auto control panel, you can manage the essential settings quickly and get the drive into action. You don't need to spend time learning the drive parameters.

Effortless drive setup

- The primary settings menu with embedded assistants provides a smart and quick way to set up the drive.
- Each setting is clearly named by its function, such as motor, ramp or limit settings.

Effortless process monitoring

- One glance at the control panel's editable home view will show you the status of the drive and the process. It offers many data visualizations including bar charts, histograms and trend graphs.
- See how the electrical terminals are configured, what is the actual status and gain quick access to the related settings from the I/O menu.
- Add information eg, to I/O signals, customize fault and warning messages or give the drive a unique name with the control panel's text editor.
- Connect the PC tool to the drive through the USB connector on the control panel.

Control panel options

The Hand-Off-Auto control panel ACH-AP-H is included as standard in the delivery unless otherwise specified.

Option code	Description	Type designation
*	Assistant control panel**	ACS-AP-I
*	Control panel with Bluetooth interface**	ACS-AP-W
+J424	Blank control panel cover (no control panel delivered)	CDUM-01
3AXD5000004419	Panel bus adapter (no control panel delivered)	CDPI-01
3AUA0000108878	Control panel mounting platform (flush mounted, requires also panel bus adapter on the drive)	DPMP-01
3AXD5000009374	Control panel mounting platform (surface mounted, requires also panel bus adapter on the drive)	DPMP-02
3AXD50000010763	Door mounting kit for the panel (for one drive, contains both DPMP-02 and CDPI-01)	DPMP-EXT

* For further information please contact your local ABB

** Also compatible with ACS880 drives

Effortless drive maintenance

- Faults or warnings are quickly resolved as the help key provides context sensitive guidance and troubleshooting instructions.
- Powerful manual and automatic backup and restore functions (with name, date, content and all drive settings and parameters).

Effortless drive diagnostics

- “Active inhibits” view under the Diagnostics menu allows the drive to detect root causes for denied start request and informs the user about it when there is an active inhibit preventing the drive from starting.
- The limit info view allows user to see the reason that the drive is not following the reference currently or within the last 60 seconds.



Save time, ease troubleshooting and improve drive performance with ABB smartphone apps

Better connectivity and user experience with Drivetune

Easy and fast access to product information and support

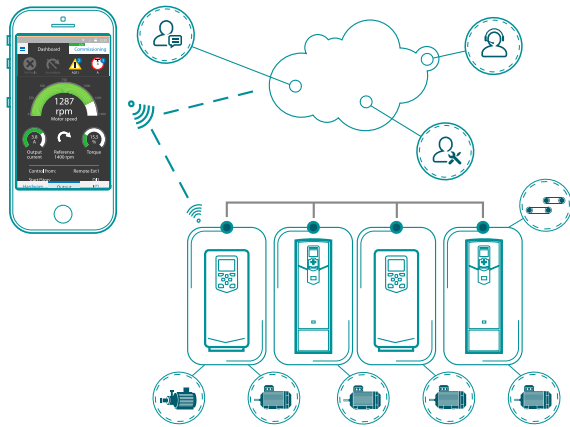

Manage your drives and the process lines and machines they control

Easy access to cloud-based drive and process information from anywhere via online connection



Startup, commission and tune your drive and application

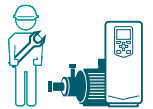

Simplified user guidance with instant access to drive status and configuration



Performance optimization via drive troubleshooting features and fast support



Services and support on the go with Drivebase

Search for support documents and contacts

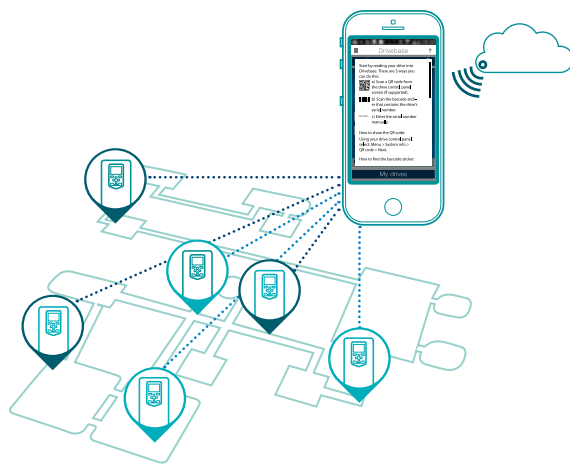

Maintain and service all your installed drives on one or multiple sites

Get 6 months extra warranty for free by registering your drive with the Drivebase app



Access your product and service information in the cloud from anywhere



Access drive's diagnostics data



Push notifications for critical product and service updates



Access information anywhere

Download the apps via QR codes or directly from the app stores

Drivetune for commissioning and managing drives



Drivebase for ensured reliability and reduced downtime on production sites



Quick configuration for unpowered drives

Cold configuration adapter CCA-01 provides a serial communication interface for unpowered ACQ580 drives, among other selected drives. With the adapter, safety isolation of both serial communication and control board power supply is possible. The power supply is taken from a PC USB port.

Cold configurator adapter

Ordering code	Description	Type designation
3AXD50000019865	Cold configurator adapter, packed kit	CCA-01



PC tool for drive monitoring and process tuning capabilities

The Drive composer PC tool offers fast and harmonized setup, commissioning and monitoring for the whole all-compatible drives portfolio. The free version of the tool provides startup and maintenance capabilities and gathers all drive information such as parameter loggers, faults, backups and event lists into a support diagnostics file with a single mouse click. This provides faster fault tracking, shortens downtime and reduces operational and maintenance costs.

The Drive composer tool is connected to the drive using the mini USB connection on the assistant control panel.

Drive composer pro offers extended functionality

Drive composer pro provides additional features such as custom parameter windows, graphical control diagrams of the drive's configuration and improved monitoring and diagnostics. The control diagrams save users from browsing long lists of parameters and help set the drive's logic quickly and easily. The tool has fast monitoring capabilities of multiple signals from several drives in the panel bus. Full backup and restore functions are also included.



Remote monitoring access worldwide

The remote monitoring tool, NETA-21, gives easy access to the drive via the Internet or local Ethernet network. NETA-21 comes with a built-in web server. Compatible with standard web browsers, it ensures easy access to a web based user interface. Through the web interface, the user can configure drive parameters, monitor drive log data, load levels, run time, energy consumption, I/O data and bearing temperatures of the motor connected to the drive.

Remote monitoring option

Ordering code	Description	Type designation
3AUA0000094517	2 x panel bus interface, 2 x 32 = max. 64 drives 2 x Ethernet interface SD memory card USB port for WLAN/3G	NETA-21



Flexible connectivity to automation networks

The drives for water and wastewater are compatible with a wide range of fieldbus protocols. The drive comes with Modbus RTU fieldbus interface as standard. The optional fieldbus adapters can easily be mounted inside the drive.

Drive monitoring

A set of drive parameters and/or actual signals, such as torque, speed, current, etc., can be selected for cyclic data transfer, providing fast data access.

Drive diagnostics

Accurate and reliable diagnostic information can be obtained through the alarm, limit and fault words, allowing easy interfacing with plantwide HMIs.

Cabling

Substituting the large amount of conventional drive control cabling and wiring with a single cable reduces costs and increases system reliability and flexibility.

Design

The use of fieldbus control reduces engineering time at installation due to the modular structure of the hardware and software and the simplicity of the connections to the drives.

Commissioning and assembly

The modular product configuration allows precommissioning of single machine sections and provides easy and fast assembly of the complete installation.

Universal communication with ABB fieldbus adapters

The ACQ580 supports the following fieldbus protocols:



Fieldbus adapters

Option code	Fieldbus protocol	Adapter
+K451	DeviceNet™	FDNA-01
+K454	PROFIBUS DP, DPV0/DPV1	FPBA-01
+K458	Modbus RTU	FSCA-01
+K473	EtherNet/IP™, Modbus TCP, PROFINET IO	FENA-11
+K475	Two port EtherNet/IP™, Modbus TCP, PROFINET IO	FENA-21

Input/output extension modules for increased connectivity

Standard input and output can be extended by using optional analog and digital input/output extension modules. The modules are easily installed in the extension slots located on the drive.

The CMOD options also enable connection to an external +24 V supply, which allows the control panel, control board, fieldbus and I/O to stay on when mains supply is cut off. With the external supply, drive diagnosis and fault finding can still be carried out.

I/O options

Option code	Description	Type designation
+L501	External 24 V AC and DC 2 x RO and 1 x DO	CMOD-01
+L523	External 24 V and isolated PTC interface	CMOD-02
+L512	115/230 V digital input 6 x DI and 2 x RO	CHDI-01



EMC - electromagnetic compatibility

The ACQ580 drive is equipped with a built-in filter to reduce high frequency emissions. The EMC product standard (EN 61800-3) category C2 is fulfilled in wall-mounted drives.

EMC standards

The EMC product standard (EN 61800-3) covers the specific EMC requirements stated for drives (tested with motor and motor cable) within the EU. EMC standards such as EN 55011 or EN 61000-6-3/4 are applicable to industrial and domestic equipment and systems including components inside the drive. Drive units complying with the requirements of EN 61800-3 are compliant with comparable categories in EN 55011 and EN 61000-6-3/4, but not necessarily vice versa. EN 55011 and EN 61000-6-3/4 do not specify cable

length or require a motor to be connected as a load. The emission limits are comparable to EMC standards according to the table below.

Domestic environments versus public low voltage networks

1st environment includes domestic premises. It also includes establishments directly connected without an intermediate transformer to a low voltage power supply network that supplies buildings used for domestic purposes. 2nd environment includes all establishments directly connected to public low voltage power supply networks.

Comparison of EMC standards

EMC according to EN 61800-3 product standard	EN 61800-3 product standard	EN 55011, product family standard for industrial, scientific and medical (ISM) equipment	EN 61000-6-4, generic emission standard for industrial environments	EN 61000-6-3, generic emission standard for residential, commercial and light-industrial environment
1 st environment, unrestricted distribution	Category C1	Group 1, Class B	Not applicable	Applicable
1 st environment, restricted distribution	Category C2	Group 1, Class A	Applicable	Not applicable
2 nd environment, unrestricted distribution	Category C3	Group 2, Class A	Not applicable	Not applicable
2 nd environment, restricted distribution	Category C4	Not applicable	Not applicable	Not applicable

Mains chokes and built-in chokes

ABB cares about harmonics and we use chokes that help to mitigate noise at all operating ranges of the drive.

Du/dt filters

Du/dt filtering suppresses inverter output voltage spikes and rapid voltage changes that stress motor insulation.

Additionally, du/dt filtering reduces capacitive leakage currents and high frequency emission of the motor cable, as well as high frequency losses and bearing currents in the motor.

The need for du/dt filtering depends on the motor age and insulation. For information on the construction of the motor insulation, consult the motor manufacturer. If the motor does not fulfil the requirements of the filter selection table, the lifetime of the motor might decrease. Insulated non-driven end (N-end) bearings and/or common mode filters are also required for motor bearing currents with motors bigger than 100 kW. For more information, please see the ACQ580 hardware manual.

du/dt filter selection table

Motor type	Nominal mains voltage (U_N)	Motor insulation requirement
ABB M2 and M3 motors	$U_N \leq 500$ V	Standard insulation system.
ABB form-wound HXR and AM motors	380 V < $U_N \leq 500$ V	Standard insulation system.
ABB random-wound HXR and AM motors	380 V < $U_N \leq 500$ V	Check motor insulation system with the motor manufacturer.
Non-ABB random-wound and form-wound	$U_N \leq 420$ V	If the insulation system withstands $\hat{U}_{LL} = 1600$ V and $\Delta t = 0.2$ μ s, du/dt filtering is not required. With du/dt filtering the insulation system must withstand $\hat{U}_{LL} = 1300$ V.

U_N = Nominal mains voltage

\hat{U}_{LL} = Peak line-to-line voltage at motor terminals

Δt = Rise time, ie, interval during which line-to-line voltage at motor terminals changes from 10 to 90% of full voltage range

External du/dt filters

ACQ580-01	du/dt filter type													
	Unprotected IP00						Protected to IP22				Protected to IP54			
	NOCH0016-60	NOCH0030-60	NOCH0070-60	NOCH0120-60	FOCH0260-70	FOCH0320-50	NOCH0016-62	NOCH0030-62	NOCH0070-62	NOCH0120-62	NOCH0016-65	NOCH0030-65	NOCH0070-65	NOCH0120-65
400 v														
ACQ580-01-02A6-4	•						•				•			
ACQ580-01-03A3-4	•						•				•			
ACQ580-01-04A0-4	•						•				•			
ACQ580-01-05A6-4	•						•				•			
ACQ580-01-07A2-4	•						•				•			
ACQ580-01-09A4-4	•						•				•			
ACQ580-01-12A6-4	•						•				•			
ACQ580-01-017A-4		•						•				•		
ACQ580-01-025A-4		•						•				•		
ACQ580-01-032A-4			•						•				•	
ACQ580-01-038A-4			•						•				•	
ACQ580-01-045A-4			•						•				•	
ACQ580-01-062A-4			•						•				•	
ACQ580-01-073A-4				•						•				•
ACQ580-01-088A-4				•						•				•
ACQ580-01-106A-4				•						•				•
ACQ580-01-145A-4					•									
ACQ580-01-169A-4					•									
ACQ580-01-206A-4					•									
ACQ580-01-246A-4					•									
ACQ580-01-293A-4					•									
ACQ580-01-363A-4						•								
ACQ580-01-430A-4						•								

Cooling and fuses

Cooling

AC Q580 drives are fitted with variable speed cooling fans. The speed controlled fans cool the drive only when needed, reducing overall noise level and energy consumption.

Fuse connection

Standard fuses can be used with the ACQ580 drives. For input fuses see the table below:

Cooling air flow and recommended input protection fuses for 380 to 415 V units

Type designation	Frame size	Cooling air flow 380 to 415 V units		Recommended input protection fuses for 380 to 415 V units*			
		Air flow		IEC fuses		UL fuses	
		m ³ /h	ft ³ /min	A	Fuse type	A	Fuse type
ACQ580-01-02A6-4	R0	34	20	4	gG	6	UL Class T
ACQ580-01-03A3-4	R0	34	20	6	gG	6	UL Class T
ACQ580-01-04A0-4	R0	34	20	6	gG	6	UL Class T
ACQ580-01-05A6-4	R0	34	20	10	gG	10	UL Class T
ACQ580-01-07A2-4	R1	50	29	10	gG	10	UL Class T
ACQ580-01-09A4-4	R1	50	29	16	gG	15	UL Class T
ACQ580-01-12A6-4	R1	50	29	16	gG	15	UL Class T
ACQ580-01-017A-4	R2	128	75	25	gG	20	UL Class T
ACQ580-01-025A-4	R2	128	75	32	gG	30	UL Class T
ACQ580-01-032A-4	R3	116	68	40	gG	35	UL Class T
ACQ580-01-038A-4	R3	116	68	50	gG	45	UL Class T
ACQ580-01-045A-4	R3	116	68	63	gG	50	UL Class T
ACQ580-01-062A-4	R4	134	79	80	gG	80	UL Class T
ACQ580-01-073A-4	R4	134	79	100	gG	90	UL Class T
ACQ580-01-088A-4	R5	139	82	100	gG	110	UL Class T
ACQ580-01-106A-4	R5	139	82	125	gG	150	UL Class T
ACQ580-01-145A-4	R6	435	256	160	gG	200	UL Class T
ACQ580-01-169A-4	R7	450	265	250	gG	225	UL Class T
ACQ580-01-206A-4	R7	450	265	315	gG	300	UL Class T
ACQ580-01-246A-4	R8	550	324	355	gG	350	UL Class T
ACQ580-01-293A-4	R8	550	324	425	gG	400	UL Class T
ACQ580-01-363A-4	R9	1150	677	500	gG	500	UL Class T
ACQ580-01-430A-4	R9	1150	677	700	gG	600	UL Class T

* For detailed fuse sizes and types, please see the ACQ580 HW manuals, document codes: 3AUA0000076331 and 3AXD50000027582

ABB automation products

AC500

ABB's powerful flagship PLC offering provides a wide range of performance levels and scalability within a single simple concept where most competitors require multiple product ranges to deliver similar functionality.



AC500-eCo

Meets the cost-effective demands of the small PLC market while offering total inter-operability with the core AC500 range. Web server, FTP server and Modbus-TCP for all Ethernet versions. A Pulse Train Out-put module is available for multi-axis positioning.



AC500-S

A PLC based modular automation solution that makes it easier than before to mix and match standard and safety I/O modules to expertly meet your safety requirements in all functional safety applications. "Extreme conditions" version is also offered.



AC500-XC

"Extreme conditions" modules with extended operating temperature, immunity to vibration and hazardous gases, for use at high altitudes, in humid conditions, etc. It replaces expensive cabinets with its built-in protection against dirt, water, gases and dust.



Programmability

Automation Builder integrates the engineering and maintenance for PLC, drives, motion, HMI and robotics. It complies with the IEC 61131-3 standard, and offers all five IEC programming languages for PLC and drive configuration. Automation Builder supports a number of languages and comes with new libraries, FTP functions, SMTP, SNTP, smart diagnostics and debugging capabilities.



Control panels

Our control panels offer a wide range of touchscreen graphical displays from 3.5" up to 15". They are provided with user-friendly configuration software that enables tailor made customized HMI solutions. Rich sets of graphical symbols and the relevant drivers for ABB automation products are provided. Control panels for visualization of AC500 web server applications are available.



AC motors

ABB's low voltage AC motors are designed to save energy, reduce operating costs and enable demanding motor applications to perform reliably and without unscheduled downtime. General performance motors combine convenience and easy handling seamlessly with ABB's engineering expertise. Process performance motors provide the most comprehensive and versatile set of motors for the process industries and heavy-duty applications.



All-compatible drives portfolio

The all-compatible drives share the same architecture, software platform, tools, user interfaces and options. Yet, there is an optimal drive from the smallest water pump to the biggest cement kiln, and everything in the between. When you have learned to use one drive, it is easy use the other drives in the portfolio.



Water library package

ABB's water library is compatible with the AC500 series PLC's. They provide advance pumping functions, data logging, remote access and reliable data communication. The libraries ensure saved engineering time and costs as well as ease of use with fast programming possibilities.

Drives service

Your choice, your future

The future of your drives depends on the service you choose.

Whatever you choose, it should be a well-informed decision. No guesswork. We have the expertise and experience to help you find and implement the right service for your drive equipment. You can start by asking yourself these two critical questions:

- Why should my drive be serviced?
- What would my optimal service options be?

From here, you have our guidance and full support along the course you take, throughout the entire lifetime of your drives.

Your choice, your business efficiency

ABB Drive Care agreement lets you focus on your core business. A selection of predefined service options matching your needs provides optimal, more reliable performance, extended drive lifetime and improved cost control. So you can reduce the risk of unplanned downtime and find it easier to budget for maintenance.

We can help you more by knowing where you are!

Register your drive at www.abb.com/drivereg for extended warranty options and other benefits.

Option code	Description
+P932	ACQ580 extension of warranty to 60 months from delivery

Service to match your needs

Your service needs depend on your operation, life cycle of your equipment and business priorities. We have identified our customers' four most common needs and defined service options to satisfy them. What is your choice to keep your drives at peak performance?

Is uptime your priority?

Keep your drives running with precisely planned and executed maintenance.

Example services include:

- ✓ Life Cycle Assessment
- ✓ Installation and Commissioning
- ✓ Spare Parts
- ✓ Preventive Maintenance
- ✓ Reconditioning
- ✓ ABB Drive Care agreement
- ✓ Drive Exchange

Is rapid response a key consideration?

If your drives require immediate action, our global network is at your service.

Example services include:

- ✓ Technical Support
- ✓ On-site Repair
- ✓ Remote Support
- ✓ Response time agreements
- ✓ Training

Need to extend your assets' lifetime?

Maximize your drive's lifetime with our services.

Example services include:

- ✓ Life Cycle Assessment
- ✓ Upgrades, Retrofits and Modernization
- ✓ Replacement, Disposal and Recycling

Is performance most critical to your operation?

Get optimal performance out of your machinery and systems.

Example services include:

- ✓ Advanced services
- ✓ Engineering and Consulting
- ✓ Inspection and Diagnostics
- ✓ Upgrades, Retrofits and Modernization
- ✓ Workshop Repair
- ✓ Tailored services



Operational efficiency



Rapid response



Life cycle management



Performance improvement

Drives service

A lifetime of peak performance

You're in control of every life cycle phase of your drives. At the heart of drive services is a four-phase product life cycle management model. This model defines the services recommended and available throughout drives lifespan.

Now it's easy for you to see the exact service and maintenance available for your drives.

ABB drives life cycle phases explained:

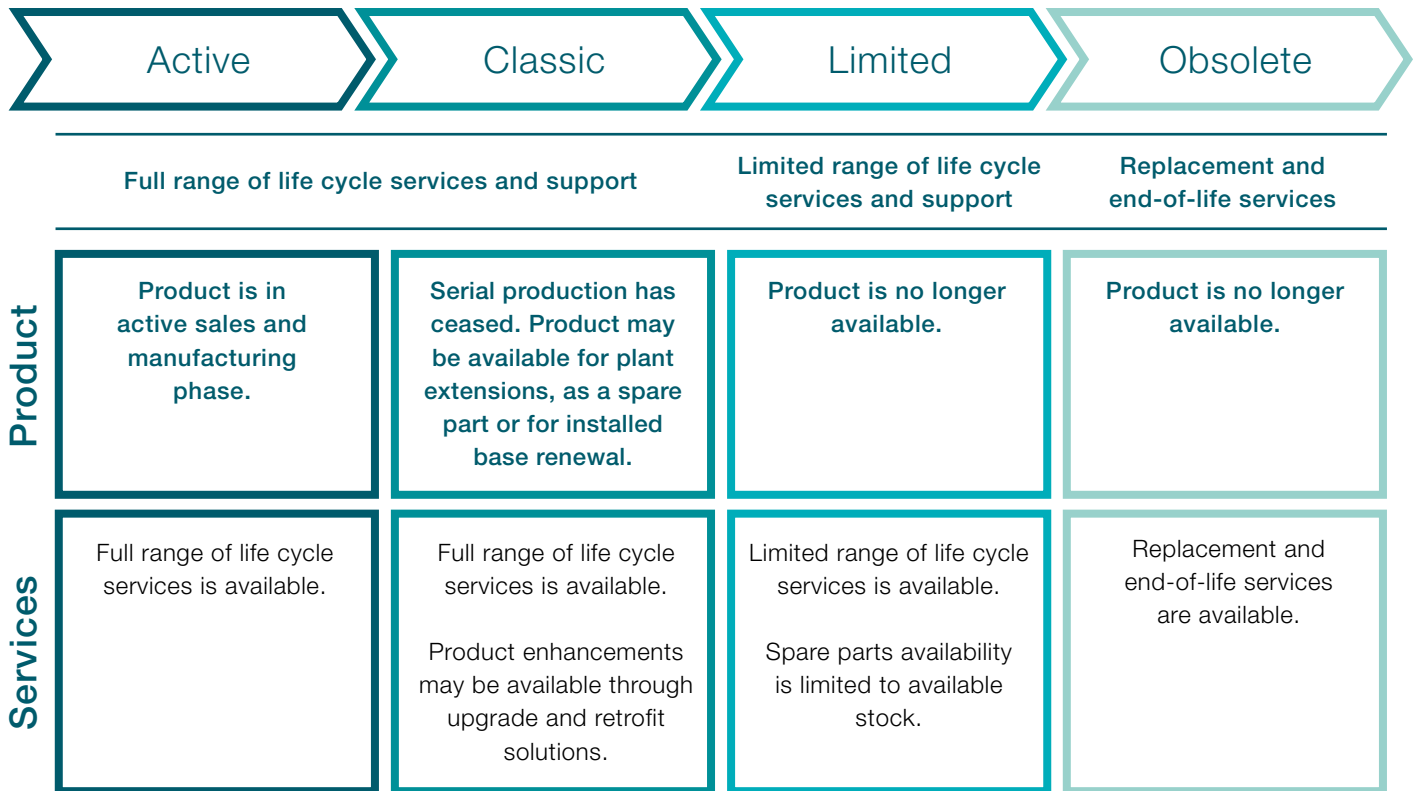

Keeping you informed

We notify you every step of the way using life cycle status statements and announcements.

Your benefit is clear information about your drives' status and precise services available. It helps you plan the preferred service actions ahead of time and make sure that continuous support is always available.

Step 1 Life Cycle Status Announcement

Provides early information about the upcoming life cycle phase change and how it affects the availability of services.

Step 2 Life Cycle Status Statement

Provides information about the drive's current life cycle status, availability of product and services, life cycle plan and recommended actions.

Contact us

For more information please contact your local ABB representative or visit:

www.abb.com/drives

www.abb.com/drivespartners

www.abb.com/motors&generators

© Copyright 2016 ABB. All rights reserved.
Specifications subject to change without notice.

Online manuals for the ACQ580 drives



3AUA0000194-172 REV A EN 30.6.2016 *12941